

Technical overview and applications



Modular

For safety tasks up to category 4 (EN 954-1) or SIL3 (IEC 61508)

- Configurable
- Can be expanded locally
- Application orientated function modules available



Compact

For safety tasks up to category 4 (EN 954-1) or SIL3 (IEC 61508)

- Configurable with application blocks
- Online diagnostics
- Software tool
- Communication interface for intelligent SICK safety sensors



Flexible

For safety tasks up to category 4 (EN 954-1) or SIL3 (IEC 61508)

- Programmable with function blocks
- Can be expanded decentrally
- Online diagnostics
- Software tool
- Network enabled



Decentral

For safety tasks up to category 4 (EN 954-1) or SIL3 (IEC 61508)

- Decentral controller in robust IP 67 enclosure rating
- For stand-alone use or in a network
- A standard PLC can directly operate the safe outputs on the remote controller using "Safety Enable"
- Quick and consistent shut-down time (<8 ms) even in a network, thanks to "Fast Shut Off" function

Applications:

- Packaging machines
- Machine tools
- Placement and handling machines

Applications:

- Presses
- Machine tools
- Placement and handling machines

Applications:

- Machine tool manufacture and systems engineering

Applications:

- Machine tool manufacture and systems engineering
- Machine tools
- Robot-assisted production



Safety controllers



Description	Number of inputs single-/dual-channel	Number of inputs expandable to single-/dual-channel	Number of outputs single-/dual-channel	Number of outputs expandable to single-/dual-channel	Expandable via	Change to the logic	Functions					Product	Page
							Signals related to pressing actions ⁴⁾	Operating mode selection	Simultaneous protective field evaluation	Diagnostics (control and sensor)	EFI – safe SICK device communication ⁶⁾		
Modular safety controller	4/2	100/50 ¹⁾	4/2	52/26 ¹⁾	Safety bus (device back panel)	Adjustable ³⁾	–	–	–	✓ ⁵⁾	–	UE410 Flexi	0-2
Compact safety controller	15/7	–	–/2	–	–	Configurable	–	✓	✓	✓	✓	UE440	0-18
							✓	✓	✓	✓	✓	UE470	0-18
Safety remote controller	12/6	1024/512 ²⁾	–/2	–	–	Programmable	–	✓	–	✓	–	UE4427	0-26
	14/8	1024/512 ²⁾	–/2	–	Network	Programmable	–	✓	✓	✓	✓	UE4457	0-26
Flexible safety controller	16/8	1024/512 ²⁾	8/4	512/256 ²⁾	Network	Programmable	–	✓	✓	✓	–	UE4470	0-34

¹⁾ Depending on module combination

²⁾ Depending on network expansion

³⁾ Via program switch

⁴⁾ Bottom dead centre, top dead centre and stop control contact

⁵⁾ Via diagnosis module on fieldbus

⁶⁾ Enhanced function interface, safe SICK device communication



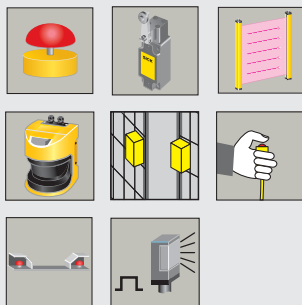

- Optimal integration of SICK safety devices
- Significant reduction in the control cabinet width
- Easy program selection using rotary switches (no software required)
- Significant reduction in the wiring effort
- Relay module
- PROFIBUS and DeviceNet integration



Further information	Page
→ Technical specifications	0-4
→ Internal circuitry	0-10
→ Dimensional drawings	0-12
→ Connection diagrams	0-13
→ Accessories	0-17
→ Services	A-2

Overview of technical specifications

Number of inputs	4 ... 100 depending on module combination
Number of safety capable outputs	4 ... 52 depending on module combination
Field bus (depending on type)	DeviceNet/PROFIBUS-DP
Program selection	Adjustable by means of rotary switch
Logical functions	OR, AND, BYPASS, Muting
Muting	✓

Product description

Behind the UE410 Flexi series is a safety control concept that enables different units and modules to be connected together as required in the specific case.

The units are of plug-in style with communication between the individual units over an internal bus.

The sensors that can be connected and the function are defined using rotary switches on the related units; except for the relay modules and the fieldbus modules that are used for integration in a higher level

controller without a safety function. These modules are output units and have no effect on the logic set or the function of the upstream units.

The UE410 series comprises the units:

- UE410-MU (main unit)
- UE410-XU (extension unit)
- UE410-8DI (input expansion unit)
- UE410-2RO/-4RO (relay module)
- UE410-PRO/UE410-DEV (diagnosis module PROFIBUS-DP/DeviceNet. CANopen in preparation)

In-system added value

A UE410 system always comprises a main unit (UE410-MU) and, as required,

additional extension units and an appropriate diagnosis module.

	Module	Number of inputs	Number of outputs	Delay time (adjustable) ³⁾	Connector technology	Field bus	Number of application diagnostic outputs
UE410-MU	Main unit	4	4	0 ... 5 s 0 ... 50 s 0 ... 300 s	Plug-in terminals/ dual level spring clamp terminals	—	—
UE410-XU	Extension unit	4	4	0 ... 5 s 0 ... 50 s 0 ... 300 s		—	—
UE410-8DI	Input expansion unit	4 ¹⁾	—	—		—	—
UE410-2RO/ UE410-4RO	Relay module	—	2/4 ²⁾	—		—	1/2
UE410-PRO/ UE410-DEV	Diagnosis module	—	—	—		PROFIBUS-DP/ DeviceNet	—

¹⁾ Dual-channel

²⁾ Relay outputs

³⁾ Only outputs Q3/Q4

→ Configuring UE410 Flexi modules: www.ue410flexi.com

Ordering information

Main unit

Number of inputs	Number of safety capable outputs	Connector technology	Delay time (adjustable) ¹⁾	Type	Part number
2 dual-channel resp. 4 single-channel	2 dual-channel resp. 4 single-channel	Plug-in terminals	0 s ... 5 s	UE410-MU3T5	6026136
			0 s ... 50 s	UE410-MU3T50	6026137
			0 s ... 300 s	UE410-MU3T300	6026138
		Dual level spring clamp terminals	0 s ... 5 s	UE410-MU4T5	6032669
			0 s ... 50 s	UE410-MU4T50	6032670
			0 s ... 300 s	UE410-MU4T300	6032671

¹⁾ Only outputs Q3/Q4

Extension unit

Number of inputs	Number of safety capable outputs	Connector technology	Delay time (adjustable) ¹⁾	Type	Part number
2 dual-channel resp. 4 single-channel	2 dual-channel resp. 4 single-channel	Plug-in terminals	0 s ... 5 s	UE410-XU3T5	6032470
			0 s ... 50 s	UE410-XU3T50	6032471
			0 s ... 300 s	UE410-XU3T300	6032472
		Dual level spring clamp terminals	0 s ... 5 s	UE410-XU4T5	6032672
			0 s ... 50 s	UE410-XU4T50	6032673
			0 s ... 300 s	UE410-XU4T300	6032674

¹⁾ Only outputs Q3/Q4

Input expansion unit

Number of inputs	Connector technology	Type	Part number
4 dual-channel resp. 8 single-channel	Plug-in terminals	UE410-8DI3	6026139
	Dual level spring clamp terminals	UE410-8DI4	6032675

Relay module

Number of normally open contacts	Number of application diagnostic outputs	Connector technology	Type	Part number
2	1	Plug-in terminals	UE410-2R03	6026144
		Dual level spring clamp terminals	UE410-2R04	6032677
4	2	Plug-in terminals	UE410-4R03	6026143
		Dual level spring clamp terminals	UE410-4R04	6032676

Diagnosis module

Field bus	Connector technology	Type	Part number
PROFIBUS-DP	Plug-in terminals	UE410-PRO3	6028407
	Dual level spring clamp terminals	UE410-PRO4	6032678
DeviceNet	Plug-in terminals	UE410-DEV3	6032469
	Dual level spring clamp terminals	UE410-DEV4	6032679

Detailed technical specifications

Main unit

General data

	UE410- MU3T5	UE410- MU3T50	UE410- MU3T300	UE410- MU4T5	UE410- MU4T50	UE410- MU4T300
Category	4 (EN 954-1)					
Safety integrity level	SIL3 (IEC 61508)					
PFD	1.7 x 10 ⁻⁵					
PFH	7.9 x 10 ⁻⁹ /h					
SFF	96 %					
DC	93 %					
Ambient operating temperature	-25 °C ... +55 °C					
Storage temperature	-25 °C ... +70 °C					
Air humidity from ... to	15 % ... 95 %, non-dewing					
Climate conditions according to	EN 61131-2					
Vibration resistance	5 Hz ... 500 Hz					
Vibration resistance (checked to)	EN 60068-2-64, EN 61131-2					
Enclosure rating	EN/IEC 60529					
Clamps	IP 40					
Housing	IP 20					
Electromagnetic compatibility (EMC)	Class A (EN 61131-2, EN 61000-6-2, EN 55011)					
Protection class	III					
Connection conductor cross-section	Single-wire or fine-wire conductor: 1 x 0.14 mm ² ... 2.5 mm ² or 2 x 0.14 mm ² ... 0.75 mm ² / fine-wire with terminal crimp according to EN 46288: 1 x 0.25 mm ² ... 2.5 mm ² or 2 x 0.25 mm ² ... 0.5 mm ²					
Connector technology	Plug-in terminals			Dual level spring clamp terminals		
Dimensions (W x H x D)	29 mm x 96.5 mm x 120.8 mm					
Weight	180 g					

Electrical data

	UE410- MU3T5	UE410- MU3T50	UE410- MU3T300	UE410- MU4T5	UE410- MU4T50	UE410- MU4T300
Supply voltage	24 V DC (19.2 V DC ... 30 V DC)					
Type of supply voltage	PELV (electrical output circuit on UE410-4RO/UE410-2RO > 25 V AC/60 V DC), PELV or SELV (electrical output circuit on UE410-4RO/UE410-2RO < 25 V AC/60 V DC)					
Power consumption	3 W					
Switch-on time	10 s					
Short-circuit protection	4A, fuse characteristic gG					
Input circuit (I1 - I4, EN, S1 - S3)	Input voltage HIGH Input voltage LOW Input current HIGH Input current LOW Switch-on time Synchronous time monitoring Muting time to operate Tolerated muting sensor signal interrupt Switch-on time ENTER button					
	15 V ... 30 V -5 V DC ... 5 V DC 3 mA (2.3 mA ... 3.6 mA) -2.5 mA ... 0.15 mA Min. 70 ms 800 ms (at program 2) 500 ms (at program 4 and 5) 61 ms, at program 3 ¹⁾ 100 ms, at program 3 ²⁾ 3 s ³⁾					
Number of inputs	2 dual-channel resp. 4 single-channel					
Control outputs (X1, X2)	Number of outputs Type of output Output voltage Output current Test pulse width Test pulse rate Load capacity					
	2 PNP semiconductors, short-circuit protected, cross-circuit monitored 18 V DC ... 30 V DC Max. 150 mA 12 ms (at program 1, 2, 4, 5, 6 on X1 and X2, at program 3.2 on X1) 52 ms (at program 3.2 on X2) 5 Hz Max. 1000 nF					
Safety outputs (Q1, Q2, Q3, Q4)	Number of safety capable outputs Type of output Output voltage Output current Response time Test pulse width Test pulse rate Load capacity Cable length Response time					
	4 PNP semiconductors, short-circuit protected, cross-circuit monitored 30 V DC 2 A 13 ms 300 µs 5 Hz 500 nF 100 m, 1.5 mm ² 13 ms (I1/I2) program 3.1, 7, 8 29 ms (I1/I2) program 1, 2, 4, 5, 6 130 ms (I1/I2) program 1 safety mat 79 ms (I1/X1) program 3.2 29 ms (I2/X2) program 3.2 13 ms (I3/I4) program 1, 2, 7, 8 29 ms (I3/I4) program 4 and 5 13 ms (EN) at cascading					
Delay time ⁴⁾	Adjustable 0 s ... 5 s	Adjustable 0 s ... 50 s	Adjustable 0 s ... 300 s	Adjustable 0 s ... 5 s	Adjustable 0 s ... 50 s	Adjustable 0 s ... 300 s
Data interface	Via field bus					

¹⁾ Time between muting condition valid (I3/I4 HIGH) and muting active

²⁾ One muting input (I3 or I4) may be LOW for this time

³⁾ Upon applying the supply voltage

⁴⁾ Only outputs Q3/Q4

Extension unit

General data

	UE410- XU3T5	UE410- XU3T50	UE410- XU3T300	UE410- XU4T5	UE410- XU4T50	UE410- XU4T300
Category	4 (EN 954-1)					
Safety integrity level	SIL3 (IEC 61508)					
PFD	1.7×10^{-5}					
PFH	$7.9 \times 10^{-9}/h$					
SFF	96 %					
DC	93 %					
Ambient operating temperature	-25 °C ... +55 °C					
Storage temperature	-25 °C ... +70 °C					
Air humidity from ... to	15 % ... 95 %, non-dewing					
Climate conditions according to	EN 61131-2					
Vibration resistance	5 Hz ... 500 Hz					
Vibration resistance (checked to)	EN 60068-2-64, EN 61131-2					
Enclosure rating	EN/IEC 60529					
Clamps	IP 40					
Housing	IP 20					
Electromagnetic compatibility (EMC)	Class A (EN 61131-2, EN 61000-6-2, EN 55011)					
Protection class	III					
Connection conductor cross-section	Single-wire or fine-wire conductor: 1 x 0.14 mm ² ... 2.5 mm ² or 2 x 0.14 mm ² ... 0.75 mm ² / fine-wire with terminal crimp according to EN 46288: 1 x 0.25 mm ² ... 2.5 mm ² or 2 x 0.25 mm ² ... 0.5 mm ²					
Connector technology	Plug-in terminals			Dual level spring clamp terminals		
Dimensions (W x H x D)	22.5 mm x 96.5 mm x 120.8 mm					
Weight	180 g					

Electrical data

	UE410- XU3T5	UE410- XU3T50	UE410- XU3T300	UE410- XU4T5	UE410- XU4T50	UE410- XU4T300
Supply voltage	24 V DC (19.2 V DC ... 30 V DC)					
Type of supply voltage	PELV (electrical output circuit on UE410-4RO/UE410-2RO > 25 V AC/60 V DC), PELV or SELV (electrical output circuit on UE410-4RO/UE410-2RO < 25 V AC/60 V DC)					
Power consumption	3 W					
Switch-on time	10 s					
Short-circuit protection	4A fuse characteristic gG					
Input circuit (I1 - I4, EN, S1 - S3)	Input voltage HIGH Input voltage LOW Input current HIGH Input current LOW Switch-on time Synchronous time monitoring Muting time to operate Tolerated muting sensor signal interrupt					
	15 V ... 30 V -5 V DC ... 5 V DC 3 mA (2.3 mA ... 3.6 mA) -2.5 mA ... 0.15 mA Min. 70 ms 800 ms (at program 2) 500 ms (at program 4 and 5) 61 ms, at program 3 ¹⁾ 100 ms, at program 3 ²⁾					
Number of inputs	2 dual-channel resp. 4 single-channel					
Control outputs (X1, X2)	Number of outputs Type of output Output voltage Output current Test pulse width Test pulse rate Load capacity					
	2 PNP semiconductors, short-circuit protected, cross-circuit monitored 18 V DC ... 30 V DC Max. 150 mA 12 ms (at program 1, 2, 4, 5, 6 on X1 and X2, at program 3.2 on X1) 52 ms (at program 3.2 on X2) 5 Hz Max. 1000 nF					

	UE410- XU3T5	UE410- XU3T50	UE410- XU3T300	UE410- XU4T5	UE410- XU4T50	UE410- XU4T300
Safety outputs (Q1, Q2, Q3, Q4)						
Number of safety capable outputs	4					
Type of output	PNP semiconductors, short-circuit protected, cross-circuit monitored					
Output voltage	30 V DC					
Output current	2 A					
Response time	13 ms					
Test pulse width	300 µs					
Test pulse rate	5 Hz					
Load capacity	500 nF					
Cable length	100 m, 1.5 mm ²					
Response time	13 ms (I1/I2) program 3.1, 7, 8 29 ms (I1/I2) program 1, 2, 4, 5, 6 130 ms (I1/I2) program 1 safety mat 79 ms (I1/X1) program 3.2 29 ms (I2/X2) program 3.2 13 ms (I3/I4) program 1, 2, 7, 8 29 ms (I3/I4) program 4 and 5 13 ms (EN) at cascading					
Delay time ³⁾	Adjustable 0 s ... 5 s	Adjustable 0 s ... 50 s	Adjustable 0 s ... 300 s	Adjustable 0 s ... 5 s	Adjustable 0 s ... 50 s	Adjustable 0 s ... 300 s
Data interface	Via field bus					

¹⁾ Time between muting condition valid (I3/I4 HIGH) and muting active

²⁾ One muting input (I3 or I4) may be LOW for this time

³⁾ Only outputs Q3/Q4

Input expansion unit

General data

	UE410-8DI3	UE410-8DI4
Category	4 (EN 954-1)	
Safety integrity level	SIL3 (IEC 61508)	
PFD	9.2 x 10 ⁻⁶	
PFH	6.1 x 10 ⁻⁹ /h	
SFF	96 %	
DC	93 %	
Ambient operating temperature	-25 °C ... +55 °C	
Storage temperature	-25 °C ... +70 °C	
Air humidity from ... to	15 % ... 95 %, non-dewing	
Climate conditions according to	EN 61131-2	
Vibration resistance	5 Hz ... 500 Hz	
Vibration resistance (checked to)	EN 60068-2-64, EN 61131-2	
Enclosure rating	EN/IEC 60529	
Clamps	IP 40	
Housing	IP 20	
Electromagnetic compatibility (EMC)	Class A (EN 61131-2, EN 61000-6-2, EN 55011)	
Protection class	III	
Connection conductor cross-section	Single-wire or fine-wire conductor: 1 x 0.14 mm ² ... 2.5 mm ² or 2 x 0.14 mm ² ... 0.75 mm ² / fine-wire with terminal crimp according to EN 46288: 1 x 0.25 mm ² ... 2.5 mm ² or 2 x 0.25 mm ² ... 0.5 mm ²	
Connector technology	Plug-in terminals	Dual level spring clamp terminals
Dimensions (W x H x D)	22.5 mm x 96.5 mm x 120.8 mm	
Weight	150 g	

Electrical data

	UE410-8DI3	UE410-8DI4
Power consumption	2 W	
Input circuit (I1 - I4, EN, S1 - S3)	Input voltage HIGH 15 V ... 30 V Input voltage LOW -5 V ... 5 V DC Input current HIGH 3 mA (2.3 mA ... 3.6 mA) Input current LOW -2.5 mA ... 0.15 mA Switch-on time Min. 70 ms Synchronous time monitoring 800 ms (at program 3 and 5)	
Number of inputs	4 dual-channel resp. 8 single-channel	
Control outputs (X1 - X8)	Number of outputs 8 Type of output PNP semiconductors, short-circuit protected, conditionally cross-circuit monitored Output voltage 18 V DC ... 30 V DC Output current Max. 150 mA Test pulse width 12 ms (at program 1, 2, 4, 5 on X1 and X2) Test pulse rate 5 Hz Load capacity Max. 1000 nF	
Safety outputs (Q1, Q2, Q3, Q4)	Response time 17 ms (for main unit and input expansion unit) mode switch selection 6, 7 on UE410-8DI 34 ms (for main unit and input expansion unit) mode switch selection 1, 2, 3, 4, 5 on UE410-8DI 134 ms (for main unit and input expansion unit) mode switch selection 2 safety mat on UE410-8DI	
Data interface	Via field bus	

Relay module

General data

	UE410-2R03	UE410-2R04	UE410-4R03	UE410-4R04
Galvanised decoupling	yes Supply circuit – output circuit and input circuit – output circuit no Supply circuit – input circuit			
Ambient operating temperature	-25 °C ... +55 °C			
Storage temperature	-25 °C ... +70 °C			
Air humidity from ... to	15 % ... 95 %, non-dewing			
Climate conditions according to	EN 61131-2			
Vibration resistance	5 Hz ... 500 Hz			
Vibration resistance (checked to)	EN 60068-2-64, EN 61131-2			
Enclosure rating	EN/IEC 60529			
	Clamps IP 40 Housing IP 20			
Electromagnetic compatibility (EMC)	Class A (EN 61131-2, EN 61000-6-2, EN 55011)			
Protection class	III			
Connection conductor cross-section	Single-wire or fine-wire conductor: 1 x 0.14 mm ² ... 2.5 mm ² or 2 x 0.14 mm ² ... 0.75 mm ² / fine-wire with terminal crimp according to EN 46288: 1 x 0.25 mm ² ... 2.5 mm ² or 2 x 0.25 mm ² ... 0.5 mm ²			
Connector technology	Plug-in terminals	Dual level spring clamp terminals	Plug-in terminals	Dual level spring clamp terminals
Dimensions (W x H x D)	22 mm x 96.5 mm x 120.8 mm			
Weight	160 g		190 g	

Electrical data

	UE410-2R03	UE410-2R04	UE410-4R03	UE410-4R04
Supply voltage	24 V DC (19.2 V DC ... 30 V DC)			
Type of supply voltage	PELV (electrical output circuit on UE410-4R0/UE410-2R0 > 25 V AC/60 V DC), PELV or SELV (electrical output circuit on UE410-4R0/UE410-2R0 < 25 V AC/60 V DC)			
Power consumption	1 W		2 W	
Short-circuit protection	6A, fuse characteristic gG (per circuit)			
Safety outputs (Q1, Q2, Q3, Q4)	2		4	
Number of normally open contacts	2		4	
Number of application diagnostic outputs	1		2	
Type of output	Potential free, positively-driven			
Switching voltage	230 V DC (5 V DC ... 275 V DC) 250 V AC (5 V AC ... 275 V AC)			
Output current	6 A			
Total current	12 A			
Response time	<30 ms			
Contact material	AgSnO2			
Surface treatment	Au (1µM)			
Usage category	AC-15/DC-13			
Rated operating current (voltage)	3 A (250 V AC), 3 A (24 V DC)			
Response time	<30 ms			
Data interface	Via field bus			

Diagnosis module

General data

	UE410-PR03	UE410-PR04	UE410-DEV3	UE410-DEV4
Ambient operating temperature	-25 °C ... +55 °C			
Storage temperature	-25 °C ... +70 °C			
Air humidity from ... to	15 % ... 95 %, non-dewing			
Climate conditions according to	EN 61131-2			
Vibration resistance	5 Hz ... 500 Hz			
Vibration resistance (checked to)	EN 60068-2-64, EN 61131-2			
Enclosure rating	EN/IEC 60529			
Clamps	IP 40			
Housing	IP 20			
Electromagnetic compatibility (EMC)	Class A (EN 61131-2, EN 61000-6-2, EN 55011)			
Protection class	III			
Connection conductor cross-section	Single-wire or fine-wire conductor: 1 x 0.14 mm ² ... 2.5 mm ² or 2 x 0.14 mm ² ... 0.75 mm ² / fine-wire with terminal crimp according to EN 46288: 1 x 0.25 mm ² ... 2.5 mm ² or 2 x 0.25 mm ² ... 0.5 mm ²			
Connector technology	Plug-in terminals	Dual level spring clamp terminals	Plug-in terminals	Dual level spring clamp terminals
Dimensions (W x H x D)	22.5 mm x 96.5 mm x 120.8 mm			
Weight	160 g			

Electrical data

	UE410-PRO3	UE410-PRO4	UE410-DEV3	UE410-DEV4
Supply voltage	24 V DC (19.2 V DC ... 30 V DC)			
Power consumption	1.6 W			
Control outputs (X1 - X4)	Number of outputs: 4 Type of output: PNP semiconductors, short-circuit protected Output voltage: 18 V DC ... 30 V DC Output current: Max. 100 mA Load capacity: Max. 100 nF			
Data interface	Field bus: RS-485, PROFIBUS-DP, VO Communication behavior: SUB-D 9 pole, female Connector technology: 0 ... 99 Slave address: 12 Mbaud Transmission rate: 1200 m (9,6 Kbit/s, 19,2 Kbit/s, 93,75 Kbit/s), 1000 m (187,5 Kbit/s), 400 m (500 Kbit/s), 200 m (1500 Kbit/s), 100 m (12000 Kbit/s)		ISO-DIS 11898 DeviceNet Group 2 Only Server Plug-in terminal 5 pole 0 ... 63 125 Kbit/s, 250 Kbit/s, 500 Kbit/s —	

Internal circuitry

Main unit UE410-MU

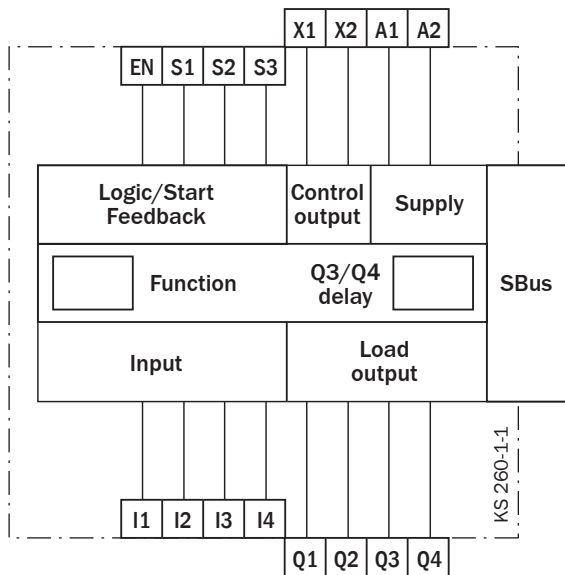

Extension unit UE410-XU

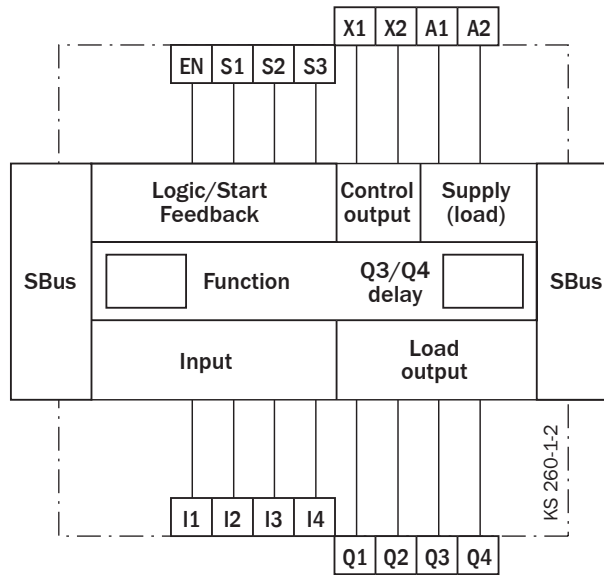

Input expansion unit UE410-8DI

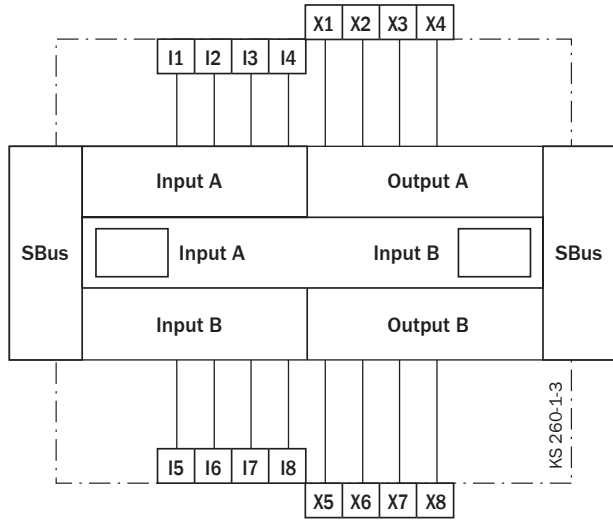

Relay module UE410-2R0

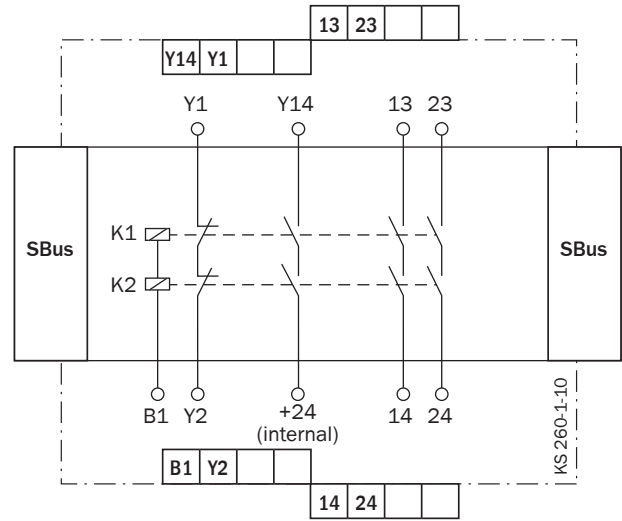

Relay module UE410-4R0

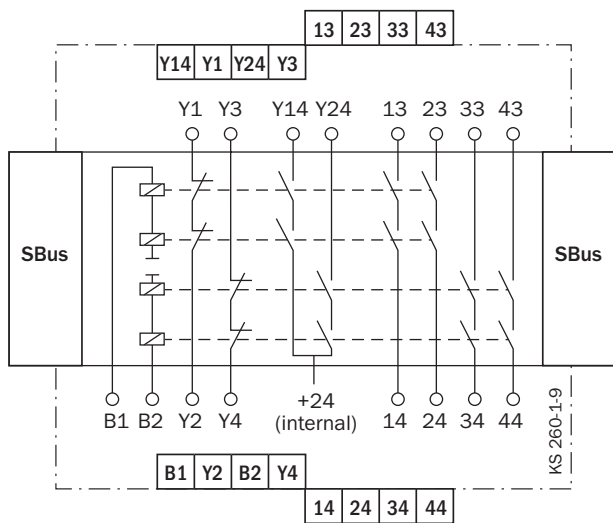

Diagnosis module UE410-PRO for PROFIBUS-DP

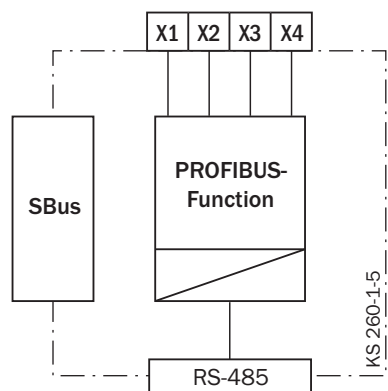

Diagnosis module UE410-DEV for DeviceNet

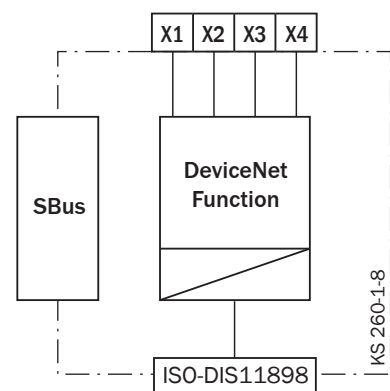

Dimensional drawings

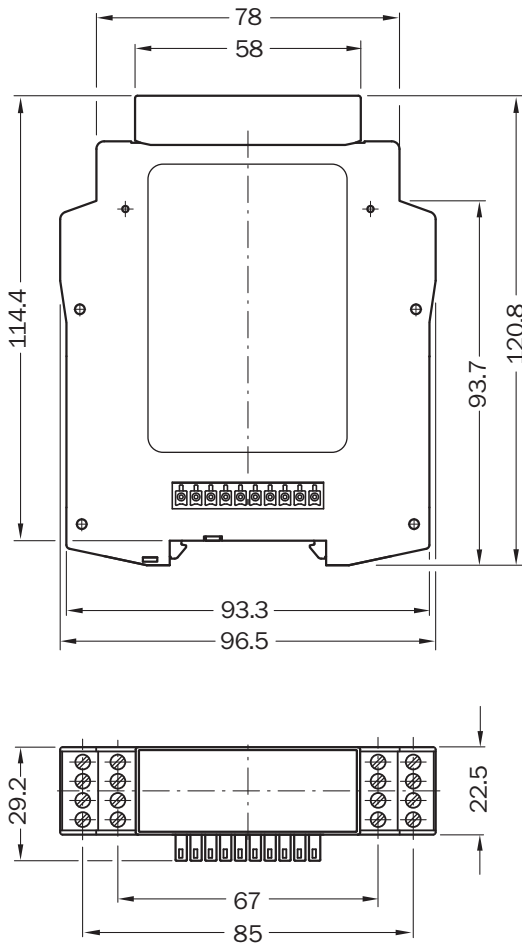

Dimensions in mm

Connection diagrams

→ You can find connection diagrams at www.sick.com

3 single-beam photoelectric safety switches WS/WE27-2 on UE410-MU

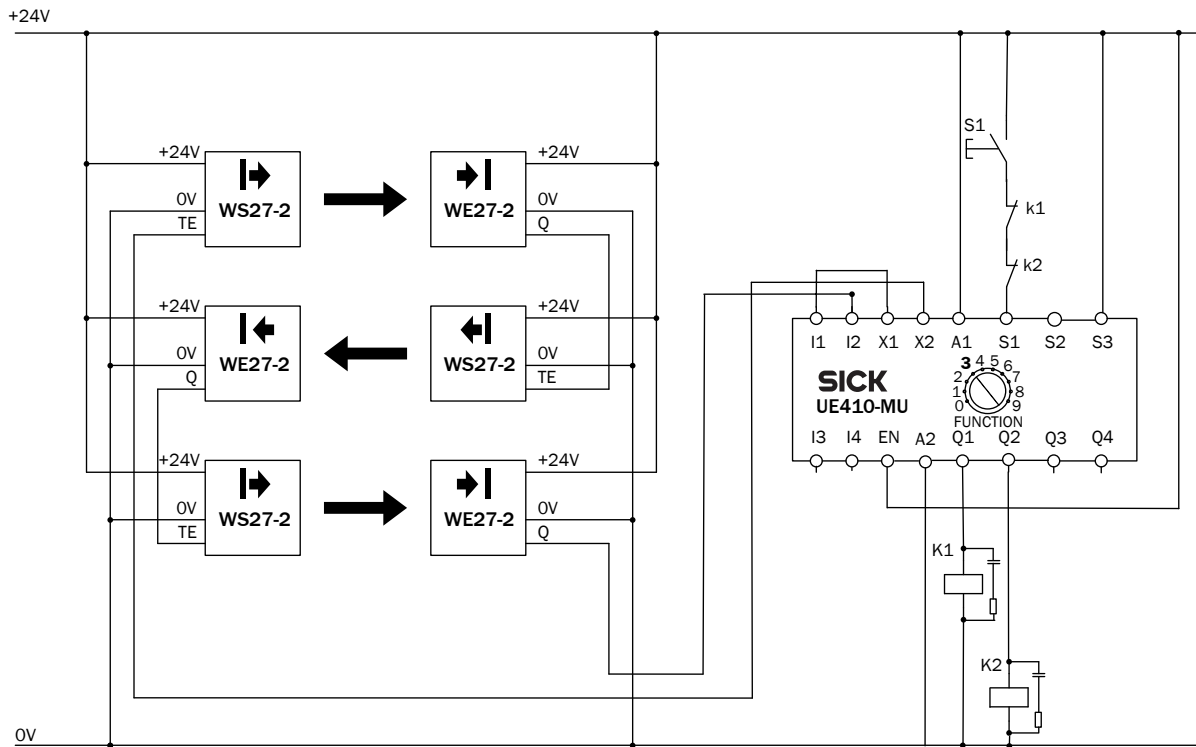

Program 3.2 with restart interlock and external device monitoring (EDM)

Two-hand control type III C on UE410-MU

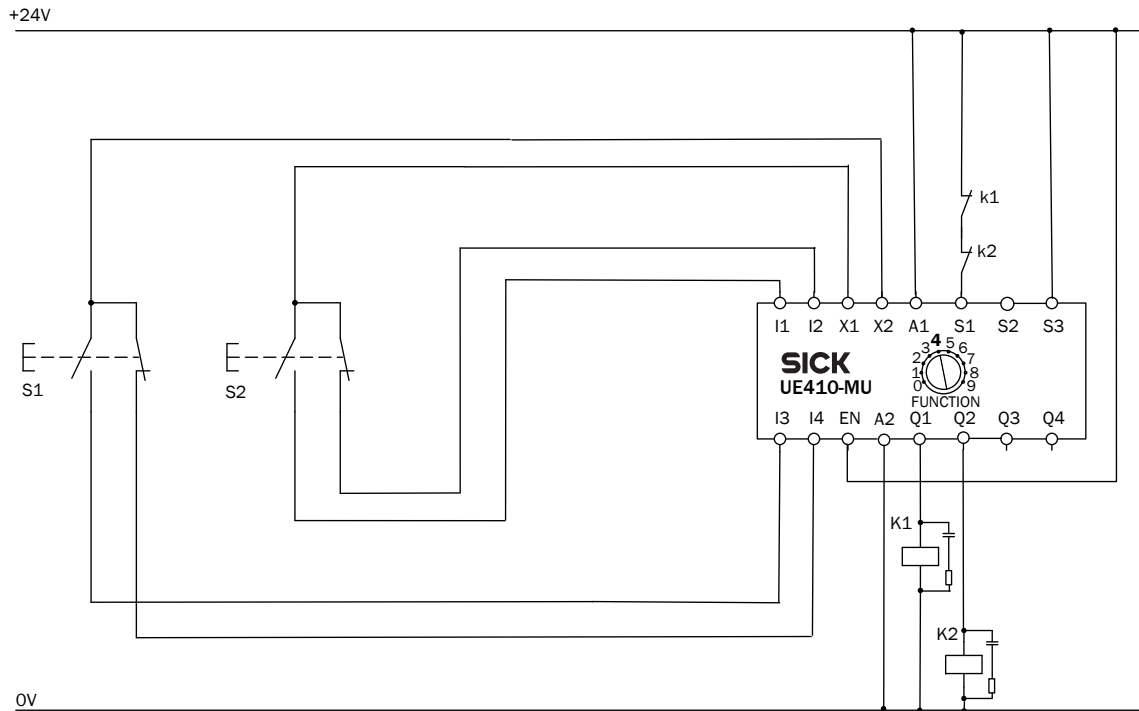

Program 4 without restart interlock and with external device monitoring (EDM)

Safety light curtain C2000 and emergency stop on UE410-MU

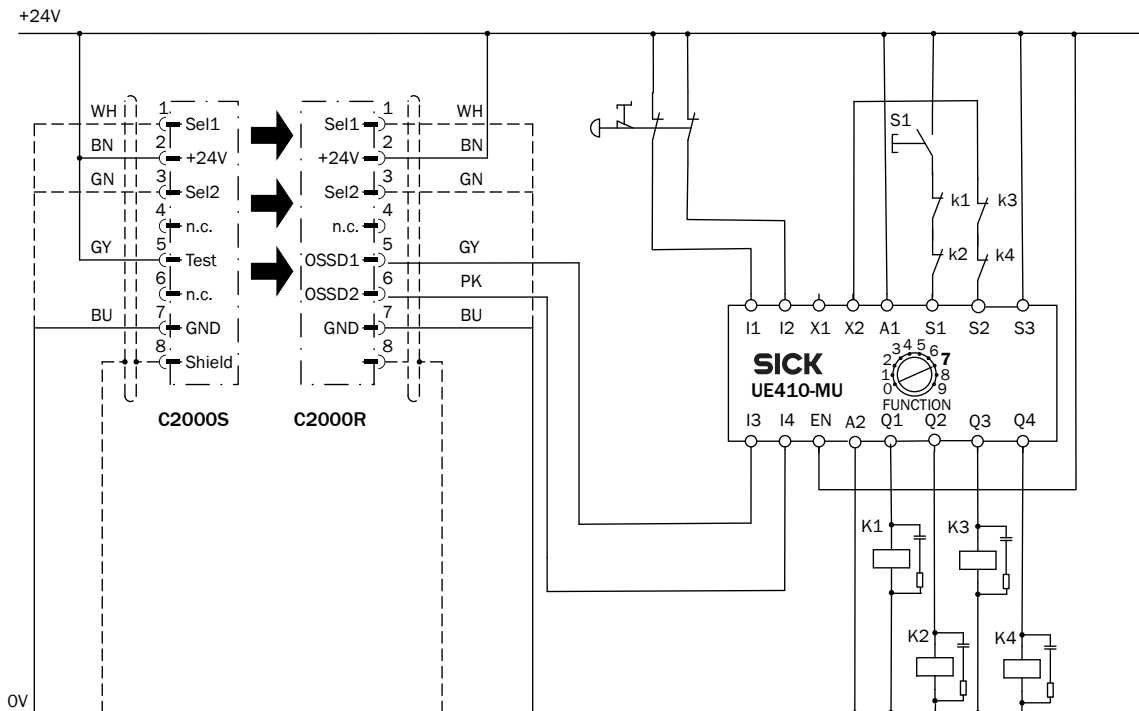

Program 7 with restart interlock and external device monitoring (EDM)

2 safety switches with separate actuator i11, 2 separate hazardous areas on UE410-MU

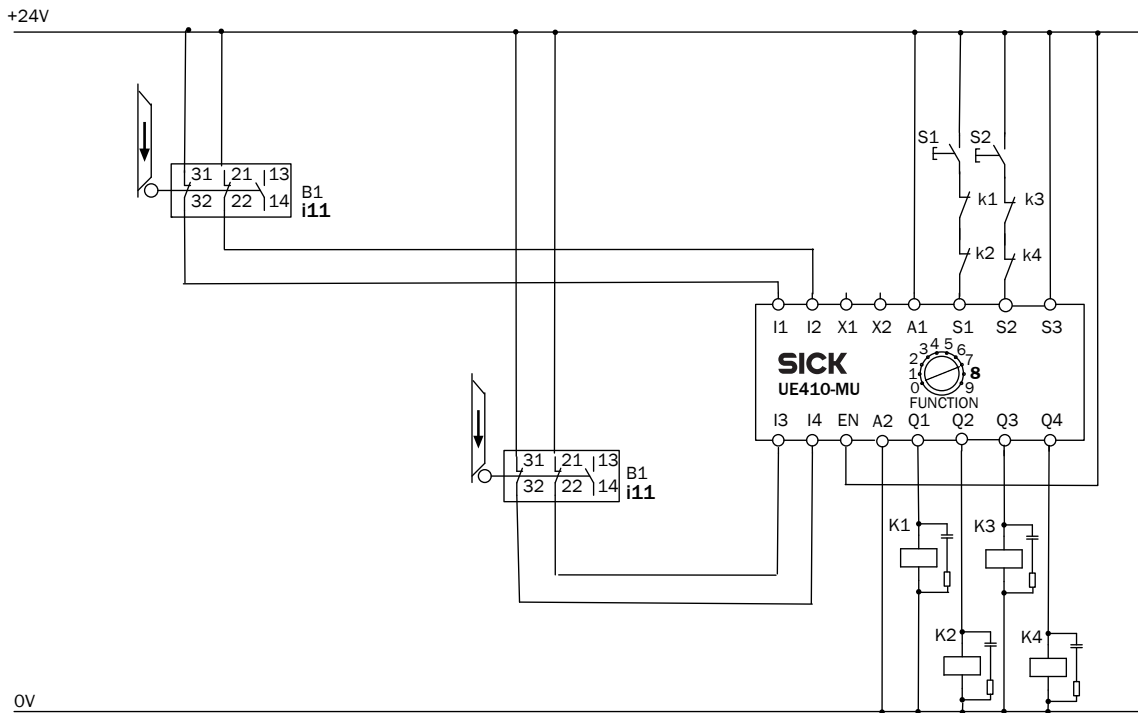

Program 8 with restart interlock and external device monitoring (EDM)

2 non-contact safety switches IN4000 on UE410-MU

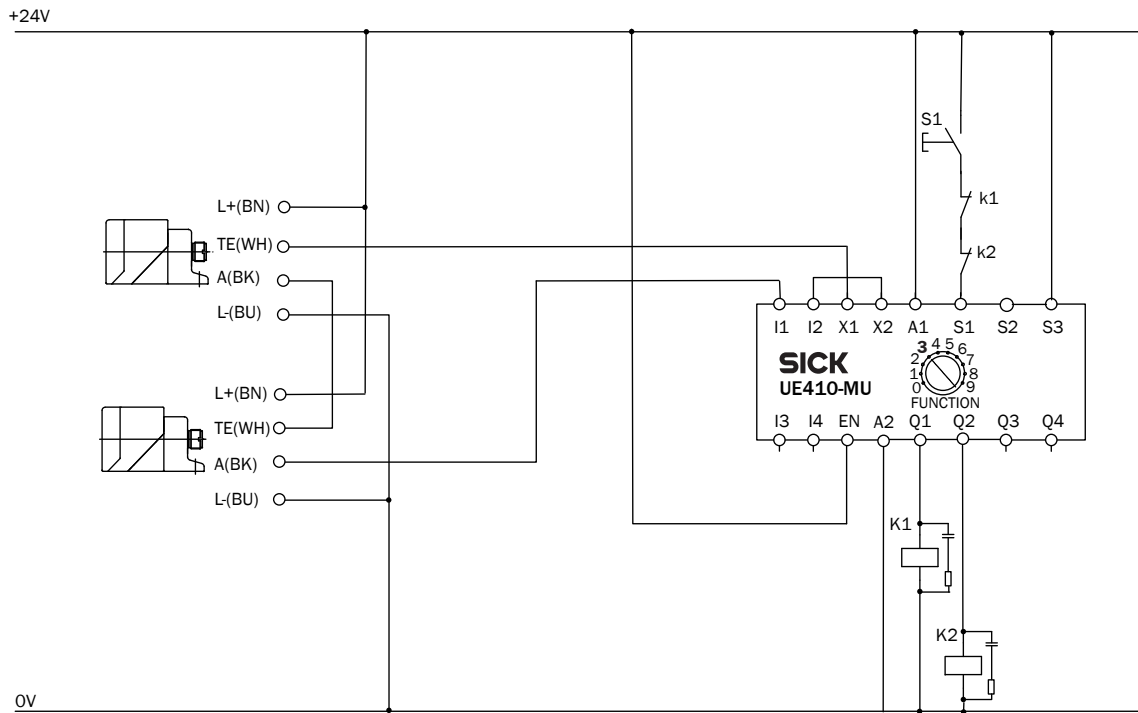

Program 3.2 with restart interlock and external device monitoring (EDM)

0

Safety light curtain C4000 with 2 muting sensors on UE410-MU

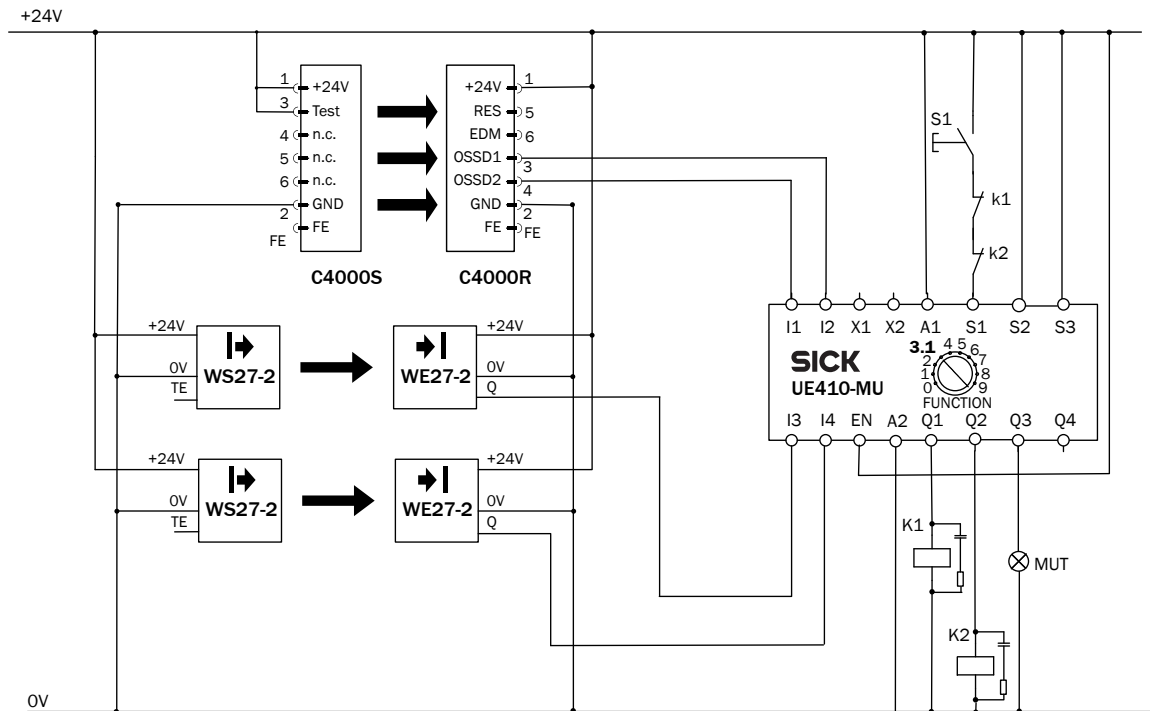

Program 3.1 with restart interlock and external device monitoring (EDM)

Accessories

Muting indicator lamp

Type of muting indicator	Cable length	Description	Remark connection cable	Part number
LED lamp	2 m	Incl. mounting kit	Incl. connection cable	2019909
	10 m			2019910
Indicator lamp (bulb)	—		Connecting cable not included	2020743

➔ Configuring UE410 Flexi modules: www.ue410flexi.com

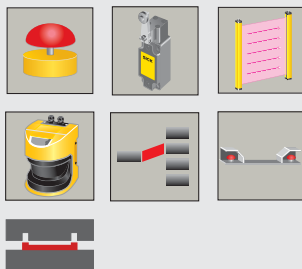

- Online monitoring
- CDS interface
- Simple drag and drop programming
- Space saving



Overview of technical specifications

Category	4 (EN 954-1)
Safety integrity level	SIL3 (IEC 61508)
Number of inputs	15 single-channel / 7 dual-channel
Number of EFI interfaces	2
Number safety applications	2
Number of operating modes	5
Number of safety outputs	2
Number of application diagnostic outputs	4
Enclosure rating	IP 20
Stop category to EN 60204	0, 1
Supply voltage	24 V DC
Response time	<10 ms

Product description

- Two independent or dependent safety applications
- Intelligent communication interface for electro-sensitive protective equipment
- 2 pairs of safe semiconductor outputs (category 4) with separate EDM and reset
- 4 wear-free semiconductor outputs
- Stopping category 0 and 1
- Reduced wiring effort due to logical linking of the safety sensors (AND, OR, NAND ...)
- Secure against tampering due to different password levels

In-system added value

- 5 operating modes
- Simple configuration via drag and drop with uniform user software CDS for SICK safety devices
- Simple replication of the application by uploading and downloading data sets
- 2 ESPE interfaces category 4 for C4000/S3000
- Function expansion for intelligent SICK sensors (simultaneous protective field monitoring S3000)

Applications

- Safety light curtains
- Photoelectric safety switches
- Safety laser scanners
- Safety switches
- Emergency stop



Further information	Page
→ Device overview and connections	0-20
→ Dimensional drawings	0-21
→ Connection diagrams	0-21
→ Accessories	0-25
→ Services	A-2

Ordering information

Type	Signals related to pressing actions	Part number
UE440-A0410	—	1023859
UE470-A0410	✓	1023862

Detailed technical specifications

General data

	UE440-A0410	UE470-A0410
Enclosure rating	IP 20 (EN/IEC 60529)	
Category	4 (EN 954-1)	
Safety integrity level	SIL3 (IEC 61508)	
Protection class	III (EN 50178)	
Connector technology	Screw-terminal connector	
Dimensions (W x H x D)	65 mm x 120 mm x 100 mm	

Electrical data

	UE440-A0410	UE470-A0410
Supply voltage	24 V DC (19.2 V DC ... 28.8 V DC) ¹⁾	
Ripple	≤10 %, within the limits of U _V	
Power consumption	Max. 4.5 A	
Number of inputs	15 single-channel / 7 dual-channel	
Number of EFI interfaces	2	
Number of operating modes	5	
Number of safety outputs	2	
Number of application diagnostic outputs	4	
Stop category to EN 60204	0, 1	
Maximum response time	<10 ms	
Input delay	0 ms ... 1000 ms, configurable	
Discrepancy time	10 ms ... 30 s, configurable	

¹⁾ The external voltage supply must be capable of buffering brief mains failures of 20 ms as specified in EN 60204-1

Functions

	UE440-A0410	UE470-A0410
Restart interlock		✓
Automatic Reset		✓
External device monitoring		✓
Signals related to pressing actions		
Bottom dead centre	—	✓
Top dead centre	—	✓
Stop control contact	—	✓
Expanded functions through the use of the safe SICK device communication EFI		✓

Device overview and connections

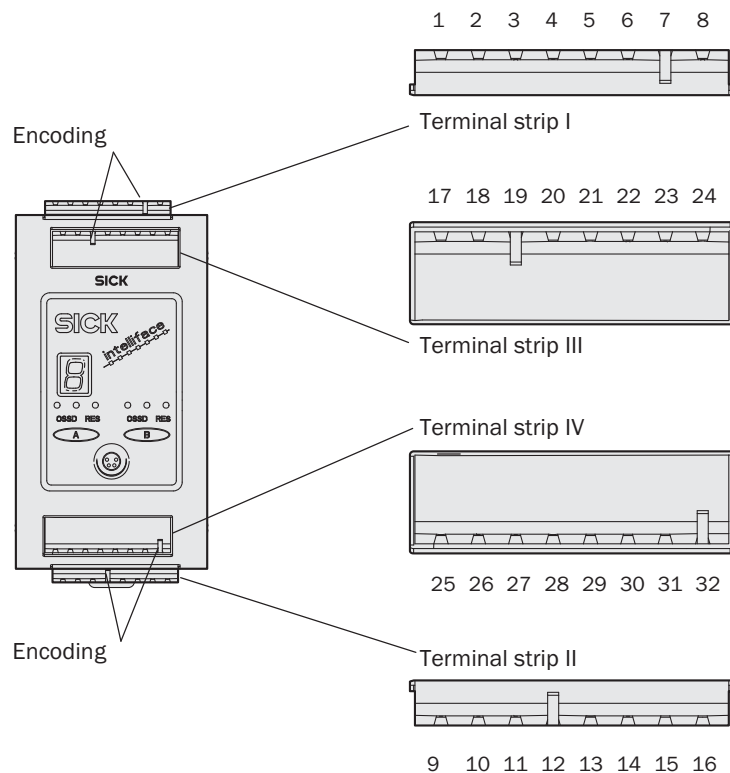

Terminal number(s)	Name convention	Functionality
1	24 V DC	V DC input (voltage supply)
2	0 V DC	V DC input (voltage supply)
3	FE	Functional earthing
4-8	I1.1 to I1.4	Inputs
14, 16, 17-20	I2.1, I2.3, I3.0 to I3.3	Inputs
26-27	I1.5 to I1.6	Inputs
30, 32	I2.0, I2.2	Inputs
21, 25	O1.0 to O1.1	Single output (single-channel) or can be used for test signals
12, 28	O1.3, O1.2	Single output (single-channel)
13, 15, 29, 31	O2.0, O2.2, O2.1, O2.3	Single output (single-channel) or can be used as switching output (dual-channel switch-off of a machine or system)
10-11, 22-23	EFI1 _B , EFI1 _A , EFI2 _A , EFI2 _B	Device communication for ESPE with EFI
9	FE	Functional earthing, for applying shielding of EFI1 (if shielding is necessary for EMC reasons)
24	FE	Functional earthing, for applying shielding of EFI2 (if shielding is necessary for EMC reasons)

0

Dimensional drawings

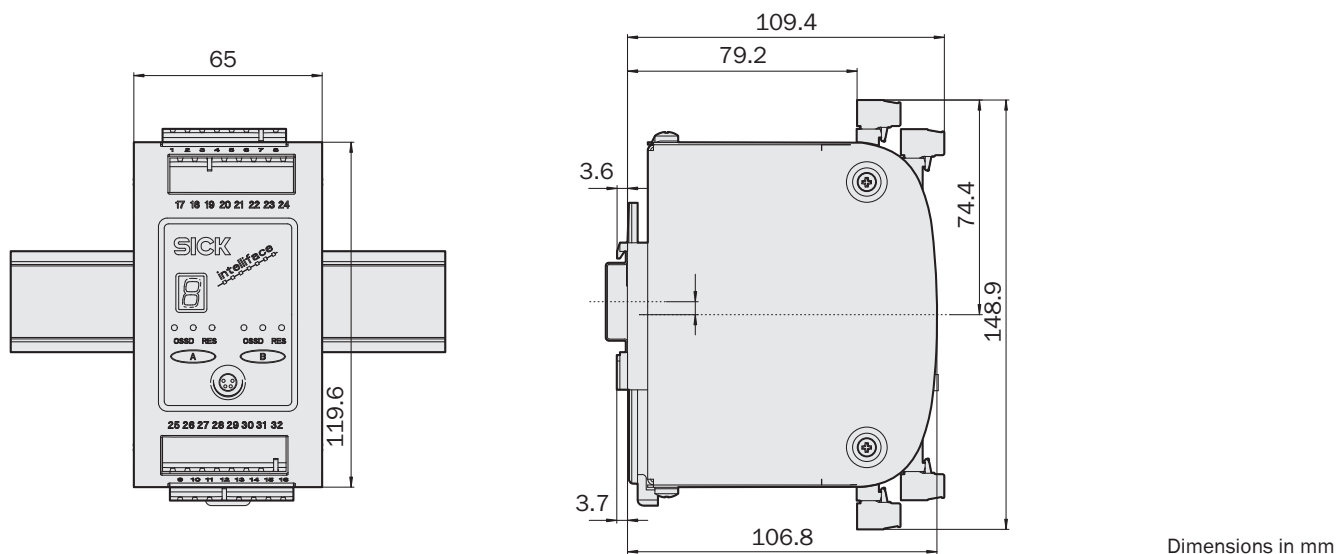

Connection diagrams

→ You can find more connection diagrams at www.sick.com

Protection of two separate accesses with UE440 and C4000 Standard/Advanced

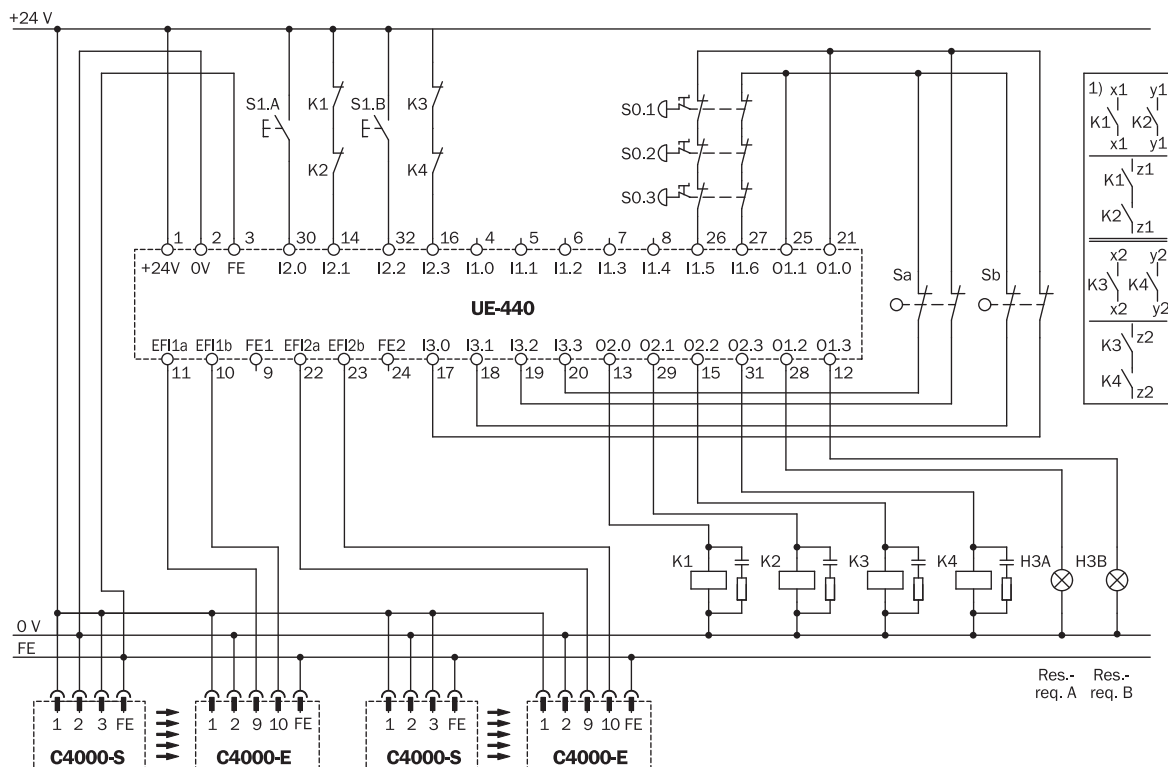

With restart interlock, external device monitoring (EDM), emergency stop, safety doors

Access protection with UE440 and M2000, point-of-operation guarding with S3000

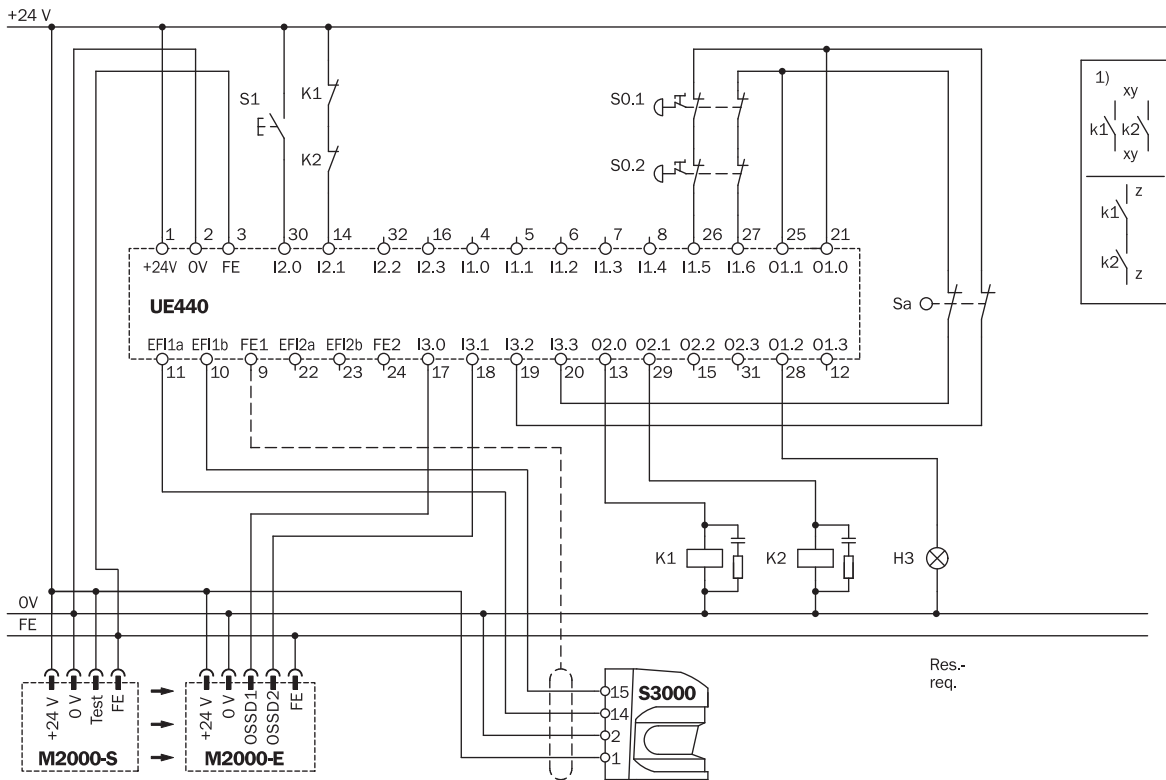

With restart interlock, external device monitoring (EDM), emergency stop, safety door

Simultaneous hazardous point protection with UE440 and S3000

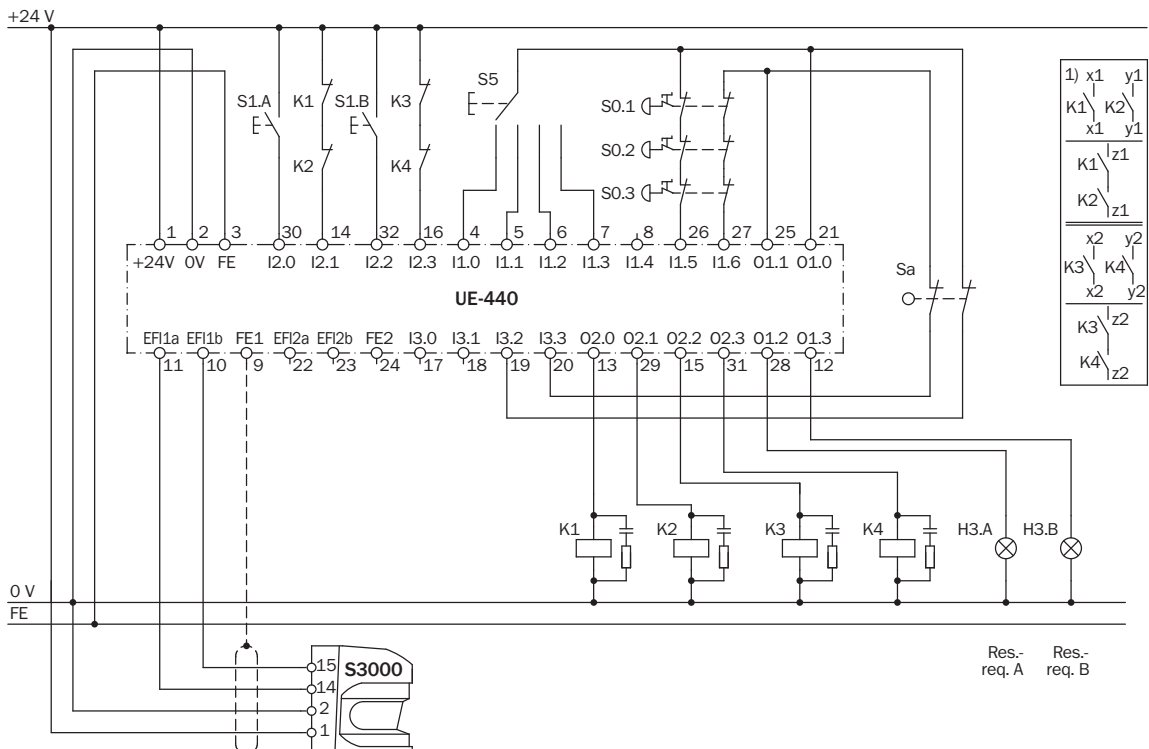

With operating mode selector switch, restart interlock, external device monitoring (EDM), emergency stop, safety doors

Hazardous point protection with UE440 and C4000, interior area protection with S3000

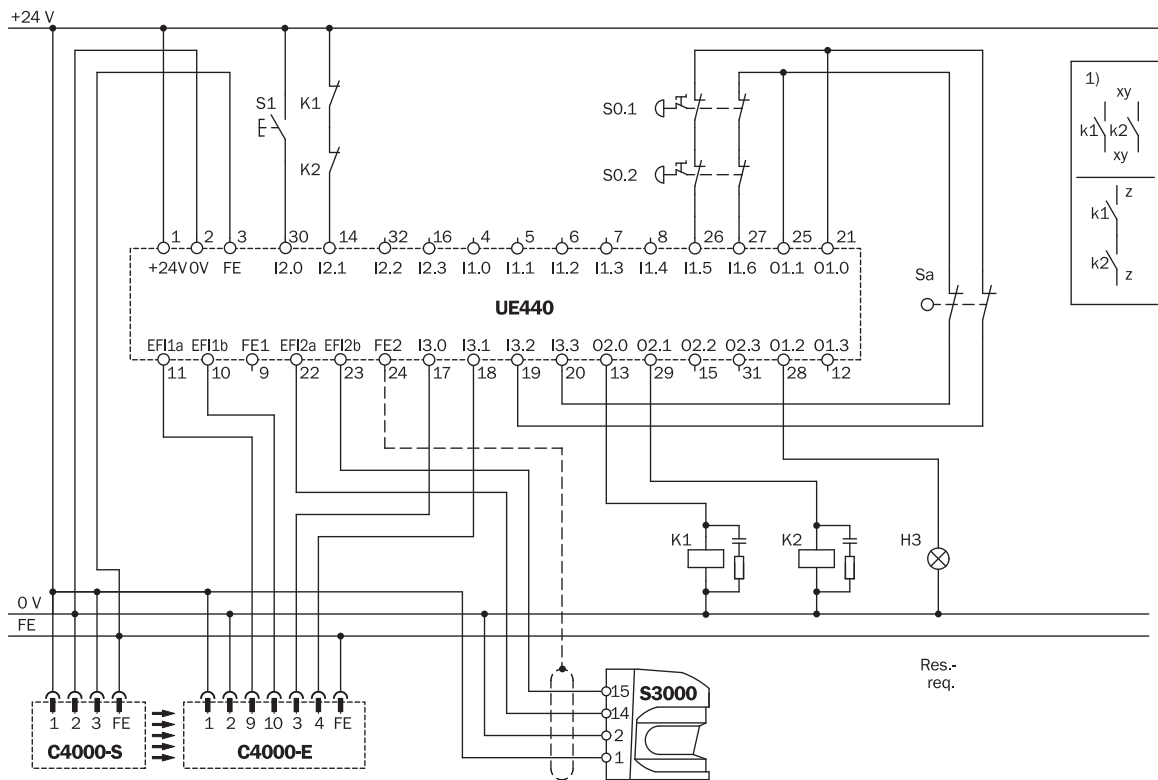

With restart interlock, external device monitoring (EDM), emergency stop, safety door

Protection of two separate hazardous points with C4000, S3000 and UE440

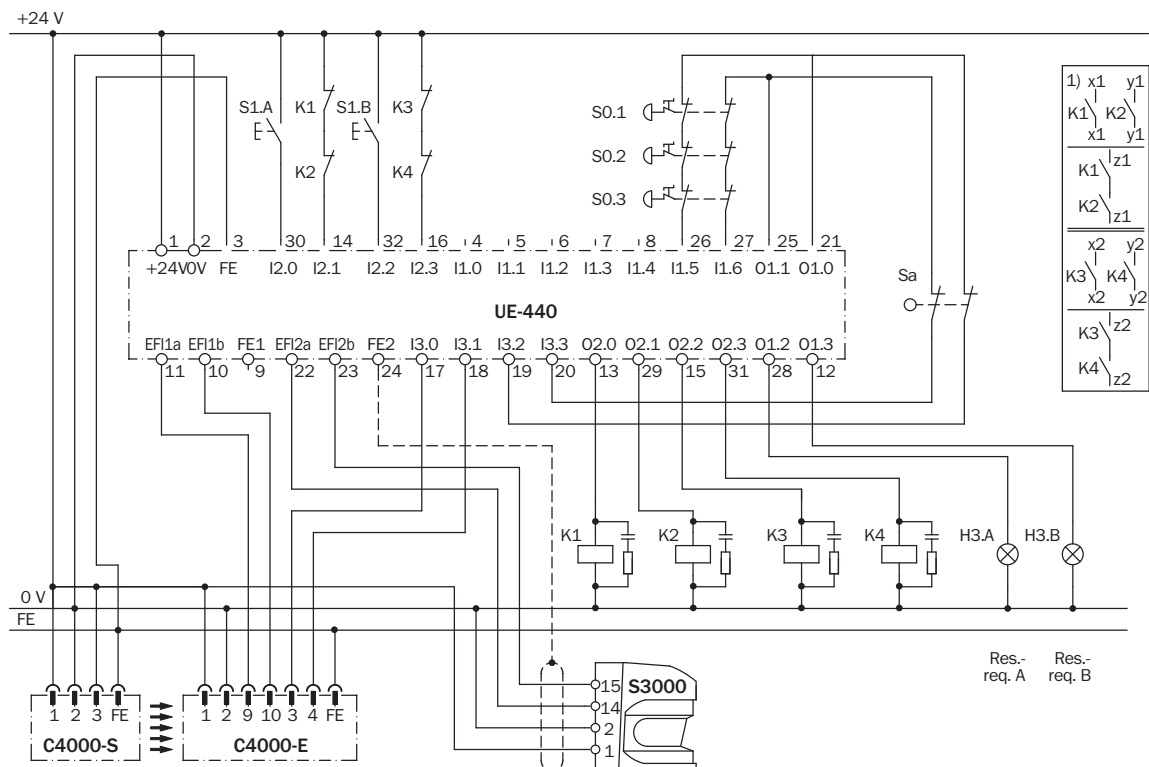

With restart interlock, external device monitoring (EDM), emergency stop, safety door

Hazardous point protection with UE470, C4000, C2000 and M2000 on a press with PSDI mode

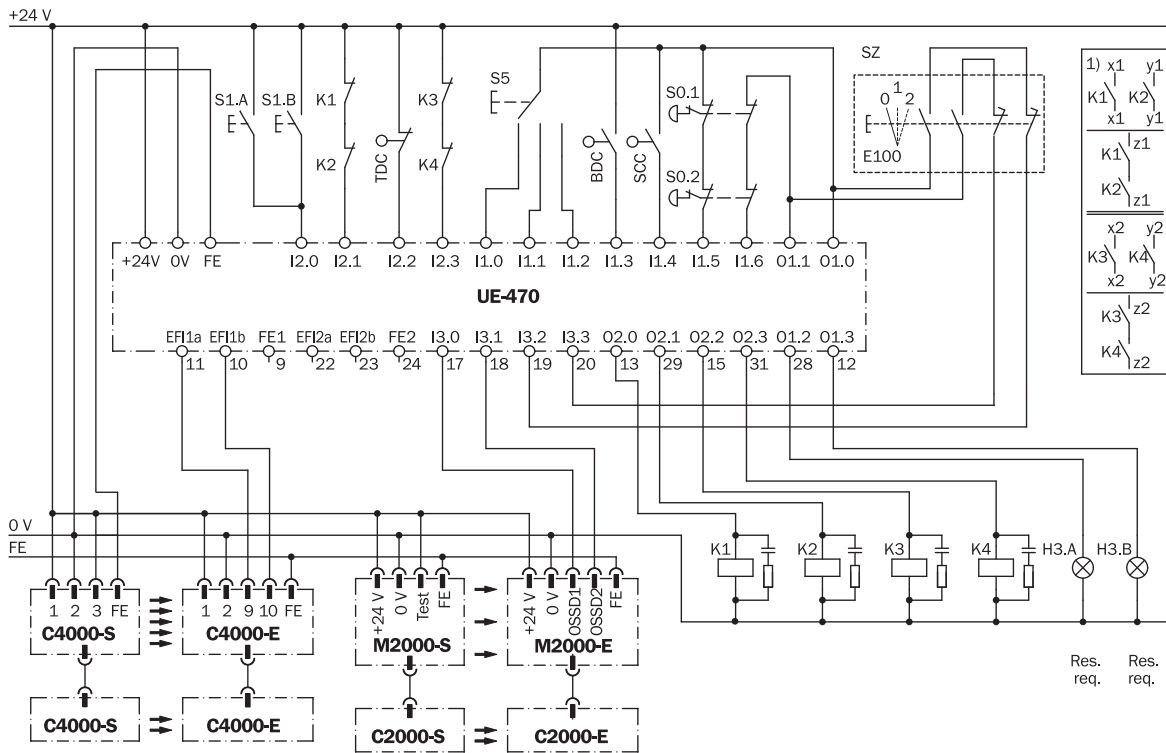

With operating mode selector switch, restart interlock, external device monitoring (EDM), machine cycle contacts BDC, TDC and SCC as well as emergency stop and enabling switch

Accessories

Connection cable

Type	Connector technology	Cable length	Part number
EFI connection cable	Stripped	50 m	6026675

Configuration software

Type	Description	Part number
CDS	CDS (Configuration & Diagnostic Software) on CD-ROM including online documentation and operating instructions in all available languages	2026875
Release code of CDS software	Enables configuration and online diagnostics of the UE440/470 and the connected EFI devices	2031323

Connection set

Type	Usage	Part number
System plug	Four pre-encoded screw-connection terminal, strips, including blank fields in bag	2029991

Configuration connection cable

Connector technology	Cable length	Part number
M8 x 4, SUB-D 9-pol	2 m	6021195
	8 m	2027649



- Solving applications up to SIL3 (IEC 61508)
- Rugged IP 67 enclosure for field mounting
- Operation as controller or as remote I/O possible
- Fixed and fast reaction time using Fast Shut-Off
- Standard PLC may control UE44x7 safety outputs
- Easy upgrade of sensors and actuators on DeviceNet Safety



Further information	Page
→ Dimensional drawings	0-28
→ Device overview and connections	0-29
→ Connection diagrams	0-30
→ Accessories	0-31
→ Services	A-2

Overview of technical specifications

Fieldbus	DeviceNet Safety
Number of safety inputs	6 dual-channel resp. 12 single-channel
Number of SDL connections	2
Number of safety capable outputs	2 dual-channel
Safety integrity level	SIL3 (IEC 61508)

Product description

SICK's UE4427 and UE4457 series IP 67 safety remote controllers integrate and evaluate all combination of safety sensors and actuators. This can either be achieved in stand alone mode or in networked applications.

Function block logic can be implemented directly at the unit, solving the application. The Safety Enable functionality allows standard masters (e.g. PLC) to control the safety outputs of the UE44x7 devices directly, without the need for an additional safety PLC.

The Fast Shut-Off functionality enables fast and constant reaction time of 8 ms through direct routing of local safety inputs to the safety outputs of UE44x7.

- Compact safety controller in IP 67 technology
- Comfortable library of certified function blocks
- Optimised system reaction times in stand alone or networked operation
- Standard PLC may control safety outputs of the device
- 6 dual-channel or 12 single-channel safety inputs on board
- Comfortable integration and diagnostics of intelligent SICK safety sensors via SICK Safety Data Link (SDL) at UE4457
- 2 dual-channel bipolar safety outputs (2A) on board

Applications

- Electro-sensitive protective equipments
- Emergency stop buttons
- Electro-mechanical safety switches
- Safety operating devices
- Control switches with lamps
- Operating mode selector switches
- Muting sensors
- Muting lamp
- Non-contact safety switch T4000 Compact



Ordering information

Functionality	Number of safety inputs	Number of SDL connections	Usage of the expanded functions on the SDL	Number of safety capable outputs	Type	Part number
Safety remote controller	6 dual-channel resp. 12 single-channel	—	—	2 dual-channel	UE4427-03DC9F0	1028304
		2	✓	2 dual-channel	UE4457-03DC9F0	1023807

Detailed technical specifications

General system data

	UE4427-03DC9F0	UE4457-03DC9F0
Fieldbus	DeviceNet Safety	
Category	4 (EN 954-1)	
Safety integrity level	SIL3 (IEC 61508)	
Supply voltage	19.2 V DC ... 28.8 V DC	
Connection type supply voltage	Mini 7/8" × 4	
Ambient operating temperature from ... to	-10 °C ... +55 °C	
Enclosure rating	IP 67	
Protection class	III (IEC 61131-2)	
Vibration resistance according to IEC 60068-2-6	0.35 mm, 10 Hz ... 57 Hz, 50 m/sec ² , 57 Hz ... 150 Hz	
Shock resistance	150 g, 11 ms (IEC 60068-2-27)	
Mounting	Location in the vicinity of the equipment	
Weight	570 g	650 g

Field-signal connections

Connection type	5-pole M12 connector	
Number of safety inputs	6 dual-channel resp. 12 single-channel	
Type of output on the field-signal input	PNP or contact	
Input voltage HIGH	11 V DC ... 30 V DC	
Input voltage LOW	-30 V DC ... 5 V DC	
Input current HIGH	5 mA	
Input delay	0 ms ... 635 ms, configurable	
Number of SDL connections	—	2
Safety outputs		
Number of safety capable outputs	2 dual-channel	
Type of output	Bipolar type	
Maximum response time	15 ms	
Switching current	2 A	
Leakage current	0.5 mA	
Test/signal outputs		
Output current per channel	700 mA	
Leakage current	Max. 0.5 mA	

DeviceNet Safety network connections

Number of safety target connections	Max. 6
Expected packet interval (EPI) setting	10 ms ... 5 ms
Single cast I/O support	16 Bytes/16 Bytes
Multi cast I/O support	16 Bytes/16 Bytes

DeviceNet network connections

	UE4427-03DC9F0	UE4457-03DC9F0
Poll connection maximum I/O transmission rate	16 Bytes/16 Bytes	
Number of standard slave connections	Max. 3	
Number of UCMM server	Max. 4	
Connection type	Mini 7/8" x 5	
DeviceNet communication rate	125 KBit/s, 250 KBit/s, 500 KBit/s, Autobaud Detection	
DeviceNet communication rate setting method	Software	
DeviceNet addressing	Via the safety network configuration tool (e.g. SICK DeviceNet Safety Configurator)	

Functions

Functionality	Safety remote controller
Usage of the expanded functions on the SDL	✓
External device monitoring	✓
Restart interlock	✓
Automatic Reset	✓
Logical functions	AND, OR, XOR, XNOR, NOT
On-delay	✓
Off-delay	✓
Door monitoring	✓
Signal routing	✓
Bidirectional communication	✓
Two-hand control systems	✓

Dimensional drawings

UE4427

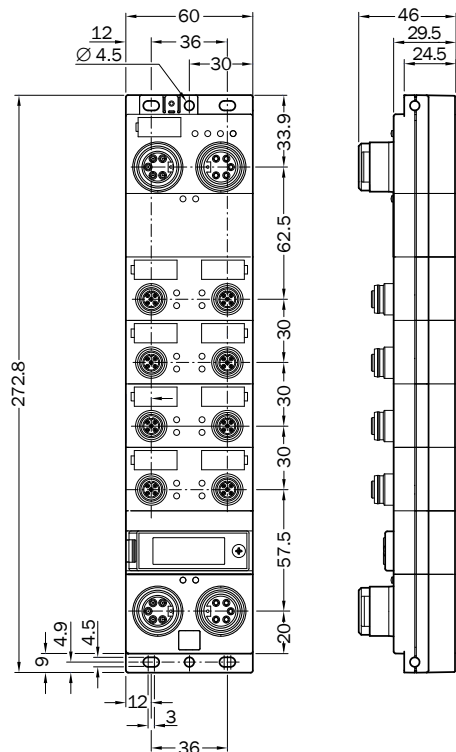

UE4457

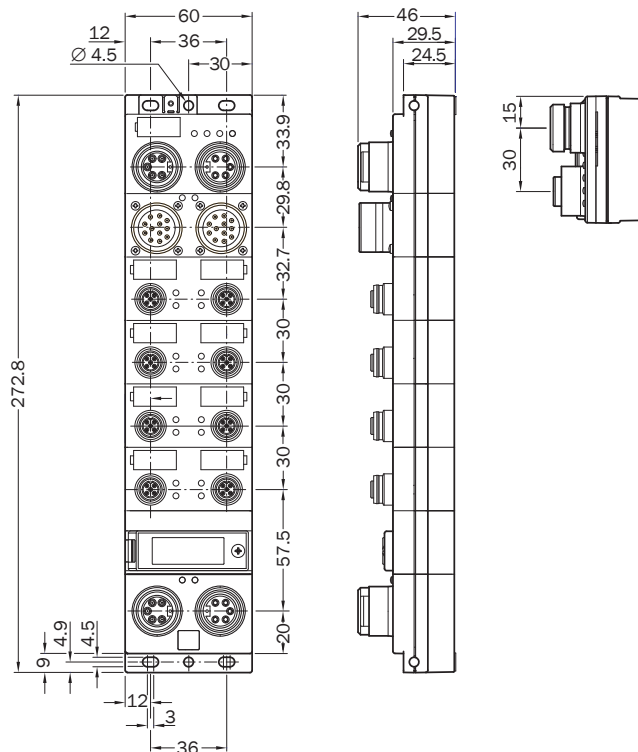

Dimensions in mm

Device overview and connections

UE4427

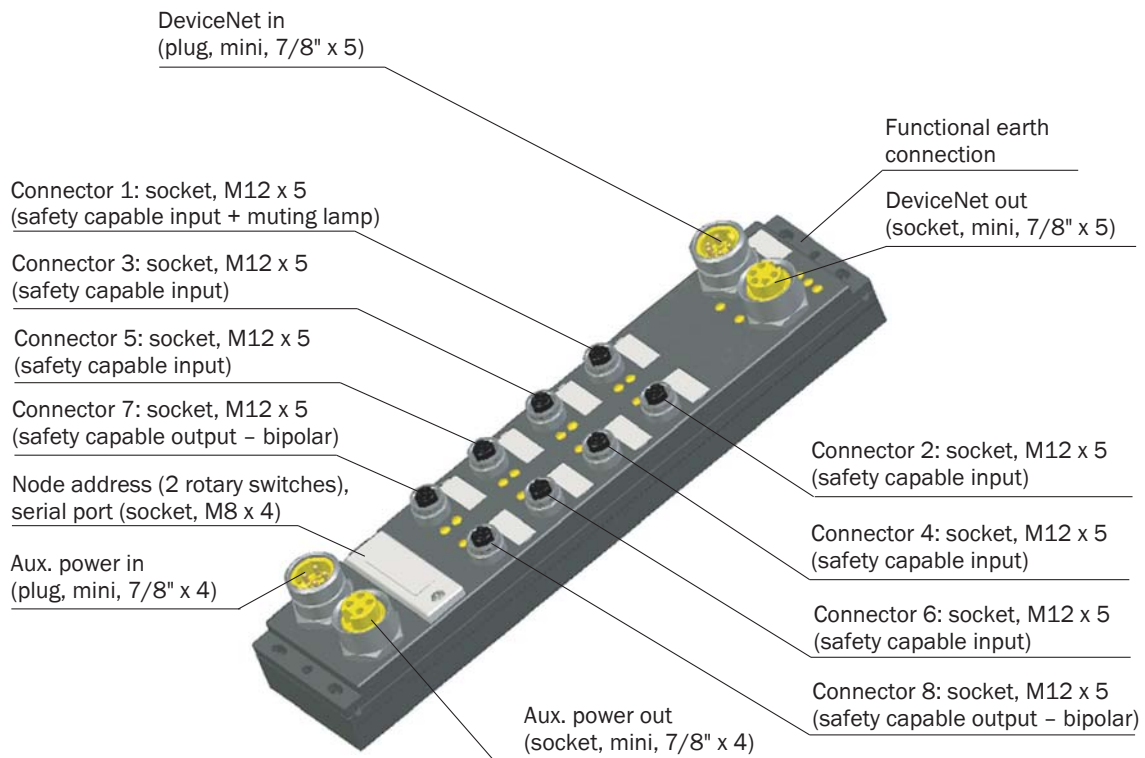

UE4457

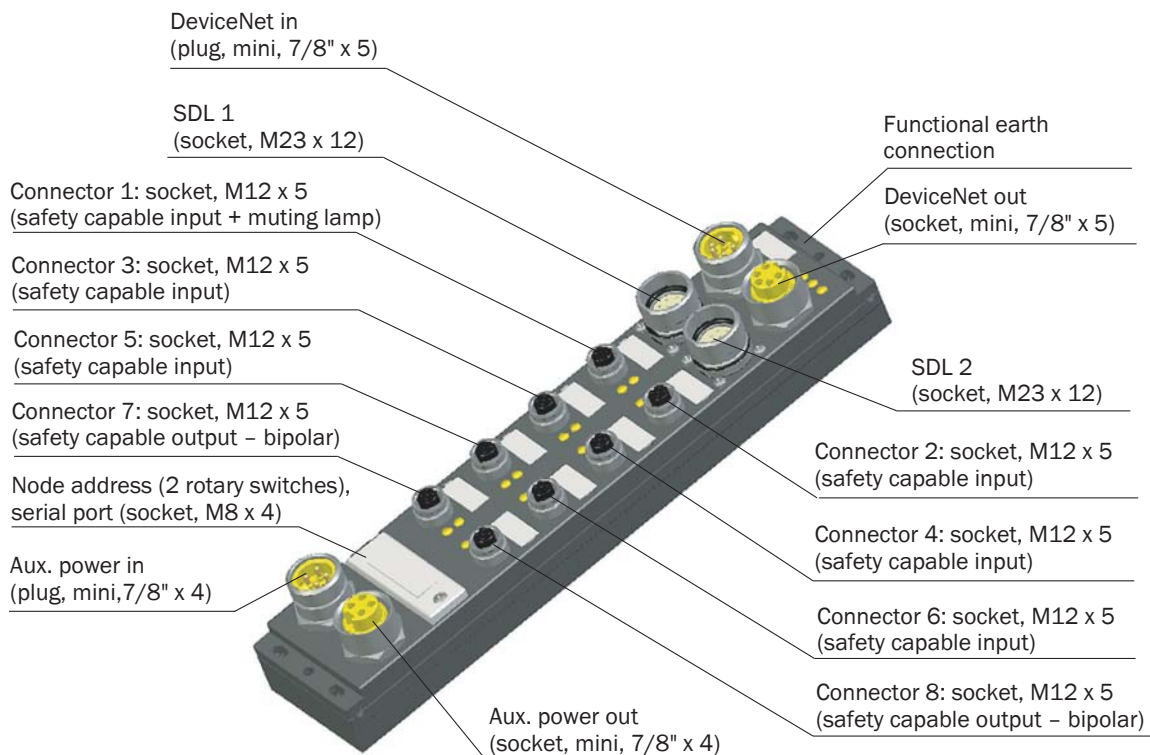

Connection diagrams

Emergency stop, emergency shutdown, safety door on the field-signal connection

Single-channel

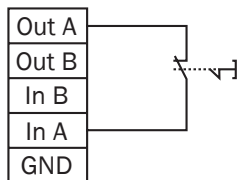

Dual-channel with common testing

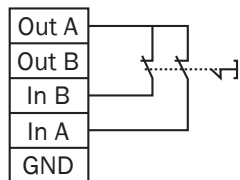

Dual-channel with isolated testing

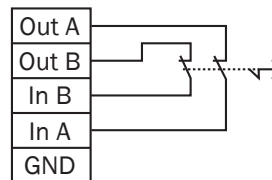

Depending on the control category required, you can realise the emergency stop using a single-channel, dual-channel with common testing or dual-channel with isolated testing.

The classification of components fitted with contacts (e.g. safety door switches and emergency stops) into a control category

depends both on the connection type (single-channel/dual-channel) and on the execution (single/redundant, testing type). You must therefore always select the appropriate switching element for the required control category and switching type.

Electro-sensitive protective equipment (ESPE) on the field-signal connection

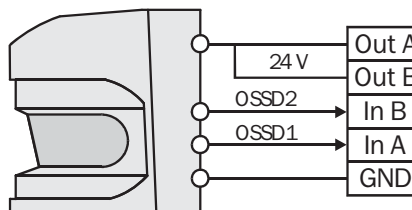
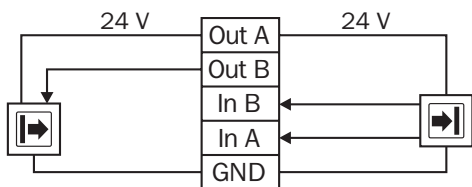

In the connection of electro-sensitive protective equipment (ESPE), sender and receiver can be considered as a system's input and output.

You can use output Out B to test the sender.

The switching outputs of the receiver are present on inputs In A and In B.

Control switch with indicator display on the field-signal connection

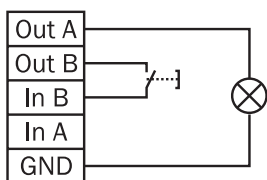

The indicator display (Out A) is being controlled via an FPLC.

Muting lamp on the field-signal connection

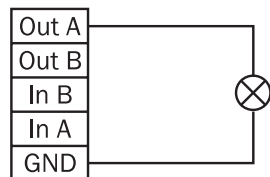

It is only permitted to connect a muting lamp to channel A of field-signal outputs 7 and 8, as only these outputs have fault monitoring.

0

Accessories

Field-signal connection, connection cables

Connection type	Connector technology	Direction of the cable outlet	Cable material	Shielded	Cable length	Part number
Plug M12 x 5	Stripped	Straight	PUR halogen free	—	2 m	6026133
					5 m	6026134
					10 m	6026135
			—	✓	2 m	6024860
					5 m	6024861
					10 m	6024862

Field-signal connection, T-junctions

Connection type	Usage	Part number
Plug M12 x 5	For the simultaneous connection of, e.g., two emergency stop buttons (single-channel) on one field-signal connection	6024744
	For the connection of sender/receiver to the the field-signal connection	6026517

Field-signal connection, connectors

Connection type	Connector technology	Connection wire cross-section	Direction of the cable outlet	Cable diameter	Shielded	Part number
Plug M12 x 5	Screwed	0.75 mm ²	Straight	—	✓	6024741
				Ø 4 mm	—	6022083
			Angled	Ø 4 mm	—	6022082

Field-signal connection, protective cap

Type	Packing unit	Part number
Protective cap	10	2019706

SDL connection, SDL connection cables

Connection type	Connector technology	Direction of the cable outlet	Connection wire cross-section	Description	Shielded	Cable length	Part number
Interconnectron plug M23 x 12	Stripped	Straight	0.75 mm ²	For the connection of the S3000 safety laser scanner	✓	2.5 m	2029337
						5 m	2029338
						10 m	2029339
						15 m	2029340
Interconnectron cable socket M23 x 11 + FE and Interconnectron plug M23 x 11 + FE	—	Plug straight/ socket straight	—	For the connection of the C4000 safety light curtain	—	0.5 m	7029160
						3 m	7029161
						7.5 m	7029162
						15 m	7029163
Hirschmann cable socket M26 x 11 + FE, Interconnectron plug M23 x 11 + FE	—	Plug straight/ socket straight	—			20 m	7029164
						2.5 m	2029131
						5 m	2025634
						10 m	2025635
						15 m	2025636

SDL connection, connectors

Connection type	Connector technology	Connection wire cross-section	Part number
Interconnectron plug M23 x 12	Crimped	0.82 mm ²	6024742

SDL connection, protective cap

Type	Part number
Protective cap	5310774

DeviceNet Safety connection, connection cables

Connection type	Cable material	Cable diameter	Cable length	Part number
Mini 7/8" x 5, male and female	PVC	Ø 6.9 mm	1 m	6030743
		Ø 6.9 mm	2 m	6030744
		Ø 6.9 mm	3 m	6030745
		Ø 6.9 mm	4 m	6030746
		Ø 6.9 mm	5 m	6030747
		Ø 6.9 mm	6 m	6030748
		Ø 12.2 mm	2 m	6030749
		Ø 12.2 mm	5 m	6030750
		Ø 12.2 mm	10 m	6030751
DeviceNet cable, thin	PVC	Ø 6.9 mm	By the meter	6030921
DeviceNet cable, thick		Ø 12.2 mm		6030756

DeviceNet Safety connection, DeviceNet connectors

Connection type	Connector technology	Direction of the cable outlet	Usage	Type	Part number
Mini 7/8" x 5, female	—	—	Panel mount	DeviceNet connection	6030807
Mini 7/8" x 5, male	—	—	Panel mount	DeviceNet connection	6030808
			—	DeviceNet terminator	6028995
Mini 7/8" x 5, female	Can be preformed	Straight	—	DOS-7805-GK	6028331
	—	Straight	—	DOS-7805-GKEND	6028329
Mini 7/8" x 5, male	Can be preformed	Straight	—	STE-7805-GK	6028332
Mini 7/8" x 5, one male and two female	—	—	—	T-connector	6030752

DeviceNet Safety connection, protective caps

Connection type	Part number
Mini 7/8" x 4 or 7/8" x 5, male	5315188
Mini 7/8" x 4 or 7/8" x 5, female	5315187

Power supply units

Input voltage	Output voltage	Maximum output current	Part number
100 V AC ... 240 V AC	24 V DC	2.1 A	7028789
		3.9 A	7028790

0

Auxiliary power supply, connection cables

Connection type	Connector technology	Direction of the cable outlet	Connection wire cross-section	Description	Cable length	Part number
Mini 7/8" x 4, female	Flying leads	Straight	1.5 mm ²	With screw lock	0.3 m	6030805
Mini 7/8" x 4, male						6030806
Mini 7/8" x 4, female	Stripped	—	—	—	2 m	6030753
			—	—	5 m	6030754
			—	—	10 m	6030755
—	—	—	—	—	By the meter	6030757

Auxiliary power supply, cable receptacles

Connection type	Connector technology	Direction of the cable outlet	Connection wire cross-section	Part number
Mini 7/8" x 4, female	Screwed	Straight	1.5 mm ²	6030803

Auxiliary power supply, connectors

Connection type	Direction of the cable outlet	Connection wire cross-section	Part number
Mini 7/8" x 4, male	Straight	1.5 mm ²	6030804

Configuration connection, configuration connection cables

Connection type	Description	Cable length	Part number
M8 x 4, SUB-D 9-pol	For connecting the configuration connection to the PC	2 m	6021195
		8 m	2027649

Configuration software

Type	Description	Part number
CDS	CDS (Configuration & Diagnostic Software) on CD-ROM including online documentation and operating instructions in all available languages	2032314
CDS plug-in for DeviceNet Safety SNCT	Provides plug-in configuration software and .EDS files for SICK DeviceNet Safety devices used with compatible third-party Safety Network Configuration Tool (SNCT). This software is already included with SICK DeviceNet Safety Configurator (2032920)	2027422

Cable cover

Connection type	Description	Type	Part number
M12	For minimising cable tampering. Sheath provides visible indication when it has been removed. Used to detect when cables have potentially been changed	Cable sheath/cover	5315186

Designation plates

Description	Packing unit	Part number
In the 9 x 20 mm frame	40	5310775



- Solving applications up to SIL3 (IEC 61508)
- Local/remote connection of safety sensors and actuators
- Decentralised evaluation of safety sensors and actuators
- Easy upgrade of installed base of sensors and actuators
- Logical combinations between sensors and actuators
- Large library of approved safety function blocks
- Remote configuration of other DeviceNet Safety™ devices via network



Overview of technical specifications

Fieldbus	DeviceNet Safety
Number of safety inputs	8 dual-channel resp. 16 single-channel
Number of safety capable outputs	4 dual-channel resp. 8 single-channel
Safety integrity level	SIL3 (IEC 61508)

Product description

SICK's UE4400 safety network controllers integrate and evaluate any combination of safety input and actuator devices into DeviceNet Safety™ networks, using local or remote safety inputs and outputs. Safety devices can now be logically combined for optimised machine safety control strategies. Applications include packaging machinery, robot cells, machine tools and transfer lines.

Status, diagnostic and error information can be easily accessed locally or through

the network. Integrated basic and application-specific function blocks are provided for simple and complex control capability. Logical operations include: AND, OR, Exclusive OR, Exclusive NOR, NOT, ON-delay timer, OFF-delay timer, restart interlock, external device monitoring (EDM), emergency stop, safety gate monitoring, ESPE/AOPD (e.g. safety light curtain), enabling switch, two-hand control, automatic reset, and operating mode selector switch.

Applications

- Electro-sensitive protective equipments
- Emergency stop buttons
- Electro-mechanical safety switches
- Safety operating devices
- Control switches with lamps
- Operating mode selector switches
- Muting sensors
- Muting lamp
- Non-contact safety switch T4000 Compact



Further information	Page
→ Dimensional drawings	0-37
→ Device overview and connections	0-37
→ Internal circuitry	0-38
→ Accessories	0-39
→ Services	A-2

Ordering information

Functionality	Number of safety inputs	Number of test/signal outputs (with current monitoring)	Type	Part number
Flexible safety controller	8 dual-channel resp. 16 single-channel	4 (0)	UE4470-22EE690	1028312

Detailed technical specifications

General system data

Fieldbus	DeviceNet Safety
Category	4 (EN 954-1)
Safety integrity level	SIL3 (IEC 61508)
Supply voltage	20.4 V DC ... 26.4 V DC
Connection type supply voltage	Spring terminal plug
Ambient operating temperature from ... to	-10 °C ... +55 °C
Enclosure rating	IP 20
Protection class	III (IEC 61131-2)
Vibration resistance according to IEC 60068-2-6	0.35 mm, 10 Hz ... 57 Hz, 50 m/sec ² , 57 Hz ... 150 Hz
Shock resistance	150 m/sec ² , 11 ms (IEC 60068-2-27)
Mounting	35 mm mounting rail (DIN 46277)
Weight	460 g

Field-signal connections

Connection type	Spring terminal plug
Number of safety inputs Type of output on the field-signal input Input voltage HIGH Input voltage LOW Input current HIGH Input delay	8 dual-channel resp. 16 single-channel PNP or contact 11 V DC ... 30 V DC 0 V DC ... 5 V DC 5 mA 0 ms ... 126 ms, configurable
Safety outputs Number of safety capable outputs Type of output Maximum response time Switching current Leakage current	4 dual-channel resp. 8 single-channel Source output (PNP) 15 ms 500 mA 0.1 mA
Test/signal outputs Number of test/signal outputs (with current monitoring) Output current per channel Leakage current	4 (0) 700 mA Max. 0.1 mA

DeviceNet Safety network connections

Number of originator connections	Max. 16
Number of safety target connections Expected packet interval (EPI) setting Single cast I/O support Multi cast I/O support	Max. 4 Minimum device cycle time 16 Bytes/16 Bytes 16 Bytes/16 Bytes

DeviceNet network connections

Poll connection maximum I/O transmission rate	16 Bytes/16 Bytes
Number of standard slave connections	Max. 2
Number of UCMM clients	8, open connections
Number of UCMM server	Max. 5
Connection type	Spring terminal block
DeviceNet communication rate	125 KBit/s, 250 KBit/s, 500 KBit/s, Autobaud Detection
DeviceNet communication rate setting method	DIP switch
DeviceNet addressing	Via the safety network configuration tool (e.g. SICK DeviceNet Safety Configurator)

Functions

Functionality	Flexible safety controller
External device monitoring	✓
Restart interlock	✓
Automatic Reset	✓
Logical functions	AND, OR, XOR, XNOR, NOT
On-delay	✓
Off-delay	✓
Door monitoring	✓
Signal routing	✓
Emergency stop switch	✓
Safety switches	✓
Opto-electronic protective devices	✓
Two-hand control systems	✓

Dimensional drawings

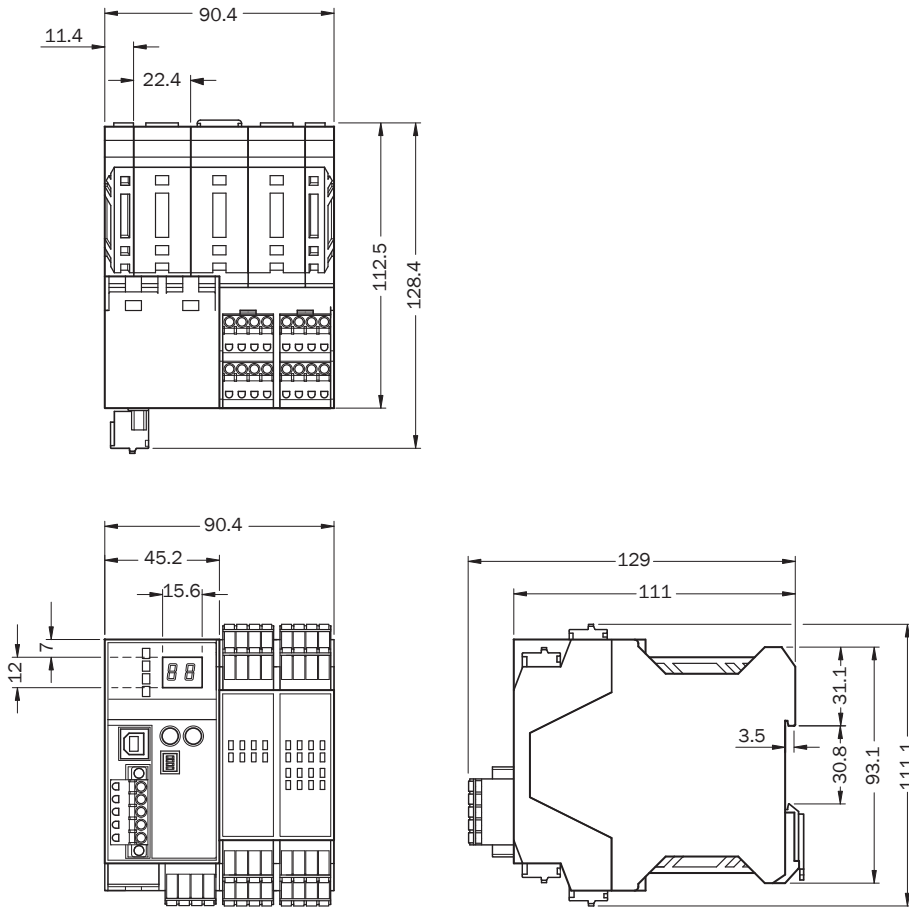

Dimensions in mm

Device overview and connections

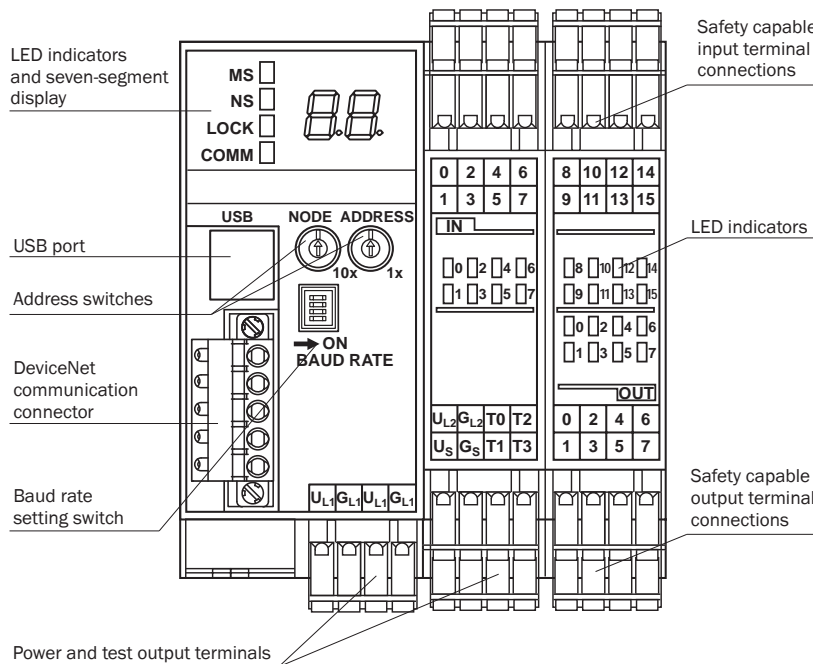

Internal circuitry

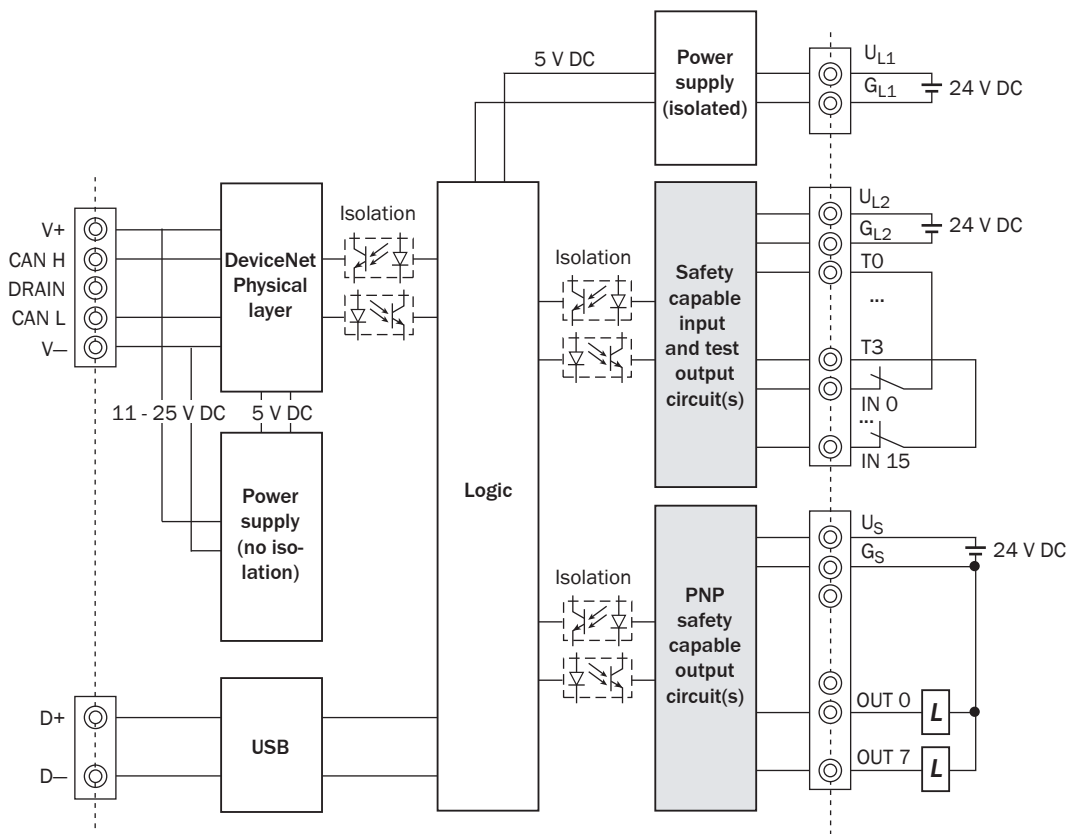

Terminal name	Description
U _{L1}	24 V DC power supply terminal for internal device power (e.g. internal logic). Both U _{L1} terminals are internally connected
G _{L1}	0 V DC power supply terminal for internal device power (e.g. internal logic). Both G _{L1} terminals are internally connected
U _{L2}	24 V DC power supply terminal for external input device and test output
G _{L2}	0 V DC power supply terminal for external input device and test output
U _S	24 V DC power supply terminal for external output device
G _S	0 V DC power supply terminal for external output device
INO to IN15	Safety capable input terminals
T0 to T3	Test/signal output terminals
OUT0 to OUT7	Safety capable output terminals

Accessories

Configuration software

Type	Description	Part number
SICK DeviceNet Safety Configurator	Enables the configuration and diagnosis of the DeviceNet and DeviceNet Safety network. Includes SICK CDS plug-in module for SICK UE4421 and configuration software plug-in for SICK UE4470 Safety Network Controller	2032920
CDS plug-in for DeviceNet Safety SNCT	Provides plug-in configuration software and .EDS files for SICK DeviceNet Safety devices used with compatible third-party Safety Network Configuration Tool (SNCT). This software is already included with SICK DeviceNet Safety Configurator (2032920)	2027422

DeviceNet Safety connection, terminal connectors

Connection type	Direction of the cable outlet	Delivery	Part number
Terminal plug with M12 x 5 connector	—	—	6030818
Spring terminal plug, 5-pole	Single entry	With screw flange	6030817
	Double entry		6030816

DeviceNet Safety connection, configuration connection cables

Connection type	Cable length	Part number
USB A to USB B	1.8 m	6030820
	4.6 m	6030819

Connection terminals

Connection type	Packing unit	Delivery	Part number
Spring terminal plug, 4-pole	9	Key inserts and instructions	6030815

Power supply units

Input voltage	Output voltage	Maximum output current	Part number
100 V AC ... 240 V AC	24 V DC	2.1 A	7028789
		3.9 A	7028790