



Ready-to-fit ATEX-compliant sensors –
after all, you carry enough responsibility already!



WT24EXi



WL24EXi



WSWE24EXi



WLL24EXi

Hazard Zone 1 – device category 2G

Occasional occurrence of an explosive gas atmosphere

Meeting the Standard's strict safety requirements means that current, performance and temperature development are strictly limited

Typical applications:

- Production and bottling of engineering gases
- Chemical industry
- Water processing



W27-3EX



W18-3EX



WTR2EX



WL24-2EX

Hazard Zone 2/22 – device category 3G/3D

Short-term and rare occurrence of explosive gas or non-conducting dust



In addition to limit values for temperature, performance or UV resistance, the Standard also prescribes a mechanical strength which cannot be achieved with standard sensors. The SICK photoelectric switches of category 3D/3G are thus equipped with a metallic housing. This housing meets the Standard's strict requirements and thus offers a ready-to-fit solution.

Typical applications:

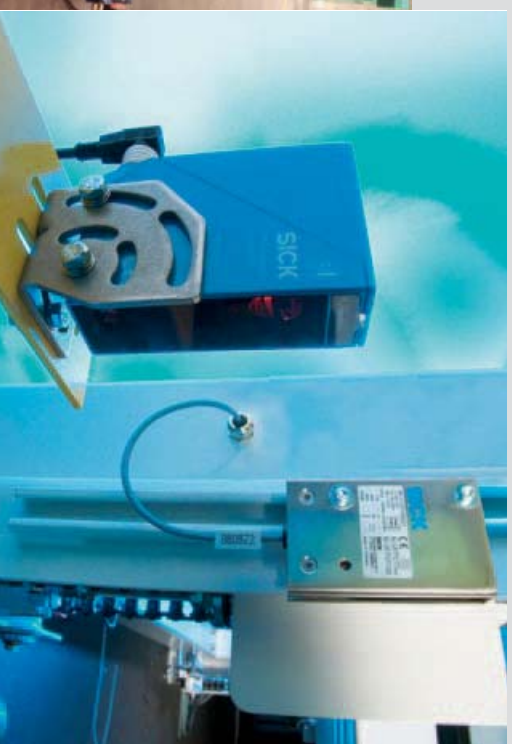

- Mills
- Timber processing
- Pharmaceutical industry



W 24 Exi: Safe and reliable switching in Ex-areas (gas)

	Photoelectric proximity switches, BGS
	Photoelectric reflex switches
	Through-beam photoelectric switches



	Photoelectric switches with fibre-optic cable
	Photoelectric switches with fibre-optic cable

The device variants used depend on the specific application:

- the WT 24 Exi photoelectric proximity switch with an adjustable scanning distance of 100 to 2,000 mm and background suppression,
- the WL 24 Exi photoelectric reflex switch which reliably detects objects located up to 8 metres away,
- the WS/WE 24 Exi through-beam photoelectric switch with a scanning range of 30 metres, and
- the WLL 24 Exi fibre-optic cable version which, depending on the type of optical head, can be used in both through-beam and proximity mode whereby the maximum distance to the object is 100 mm and 25 mm respectively.

The W 24 X Series has been developed for applications in explosive areas, in order to provide intrinsic safety according to EN 50014 and EN 50020, and approved by the “Physikalisch-Technische Bundesanstalt (PTB)” in Braunschweig, Germany. The switching outputs of the devices are designed according to EN 60947-5-6 (NAMUR). Therefore, the W 24 X Series labelled  2G EEx ia IIC T4 complies with the requirements of Category 2G according to the new Directive 94/9/EC (ATEX). The W 24 X Series devices may be used in the explosive areas “Zone 1 (gas)” and “Zone 2 (gas)”.

The sturdy zinc die-cast housings with enclosure rating IP 67 (IP 65 with WLL 24 Exi), the cable glands and plugs that can be rotated towards the bottom and rear of the sensor, and very good insensitivity to ambient light make all of these devices ideally suited for use in industrial environments.

► Ex-Zone 1:
Automatic palletisation/
depalletisation of gas
cylinders.



▼ Ex-Zone 1:
Body panel detection with photoelectric
reflex switches during fully automatic
pretreatment of body shells.

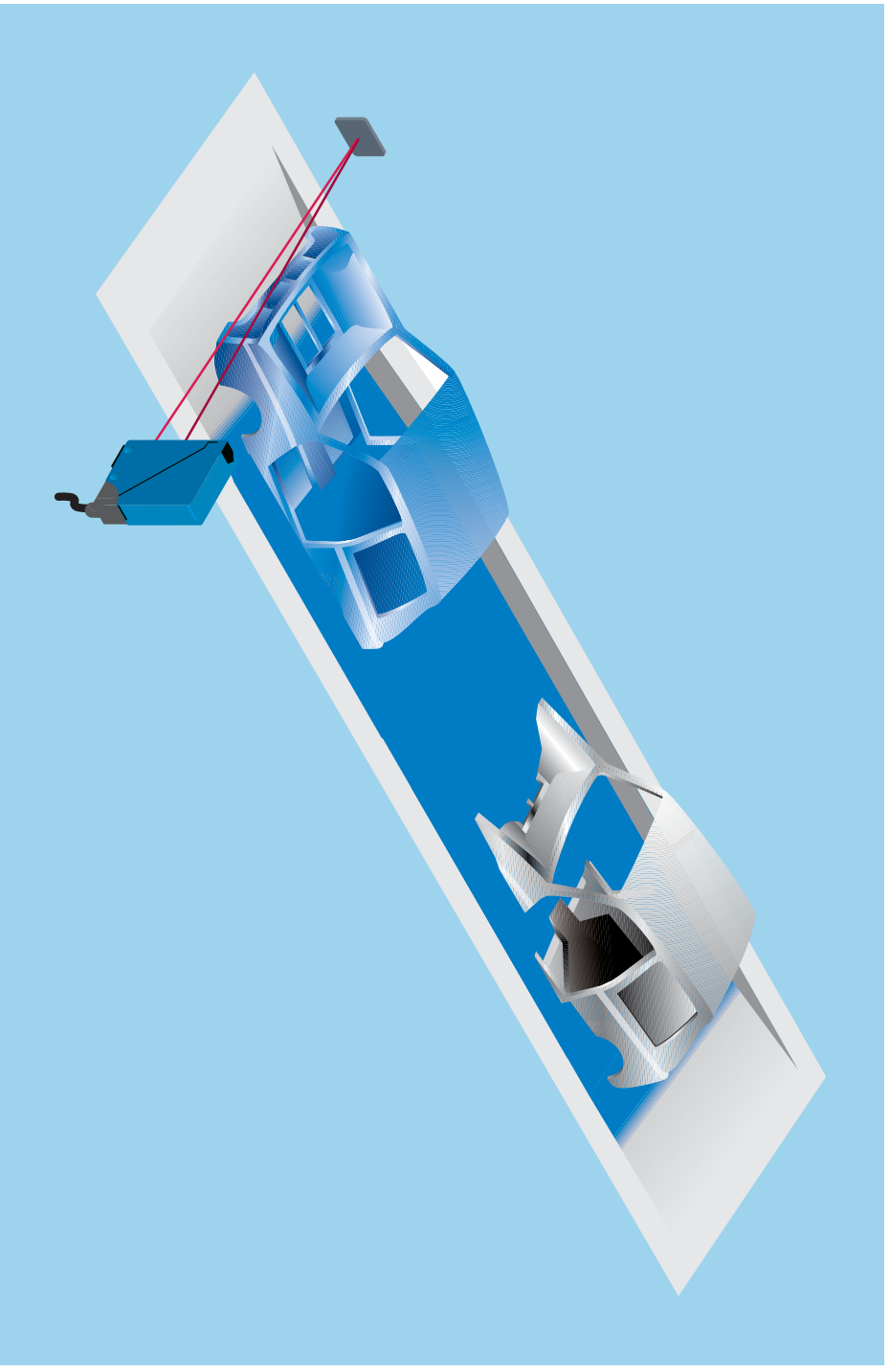

 Scanning distance
100 ... 2000 mm

Photoelectric proximity switches

- Marking:  II 2G EEx ia IIC T4 according to Directive 94/9/EC (ATEX)
- According to category 2G
- Switching output: EN 60947-5-6 (NAMUR)
- Background suppression can be set very precisely
- Infrared light





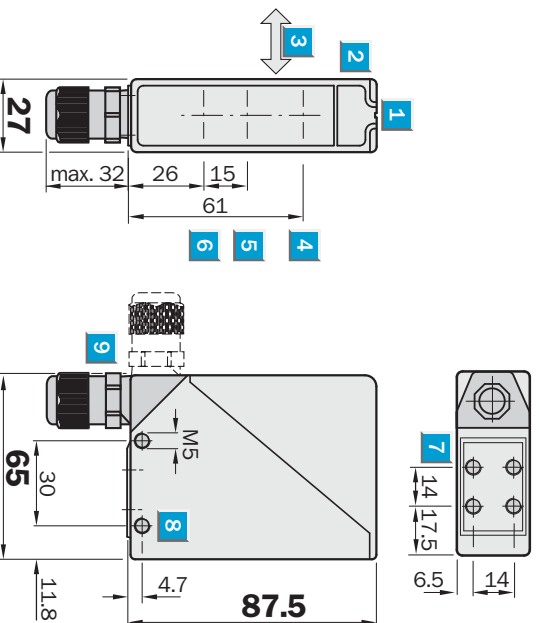





Dimensional drawing



Adjustments possible

WT 24-2X 260
WT 24-2X 460

- | | | |
|---|----|--|
|  | 1 | Alignment sight |
|  | 2 | LED signal strength indicator |
|  | 3 | Standard direction of the material being scanned |
|  | 4 | Middle of optic axis, sender |
|  | 5 | Middle of optic axis, receiver at close range |
|  | 6 | Middle of optic axis, receiver at long range |
|  | 7 | M5 threaded mounting hole, 6 mm deep |
|  | 8 | M5 threaded mounting hole |
|  | 9 | M16 screw fixing or M12 plug, rotatable by 90° |
|  | 10 | Scanning distance adjuster |

Connection types

WT 24-2X 260

WT 24-2X 460

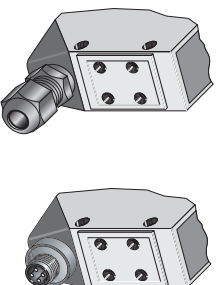

M16, terminals

4-pin, M12



See chapter Accessories
Cables and connectors
Mounting systems
Power supply units

Dimensional drawing

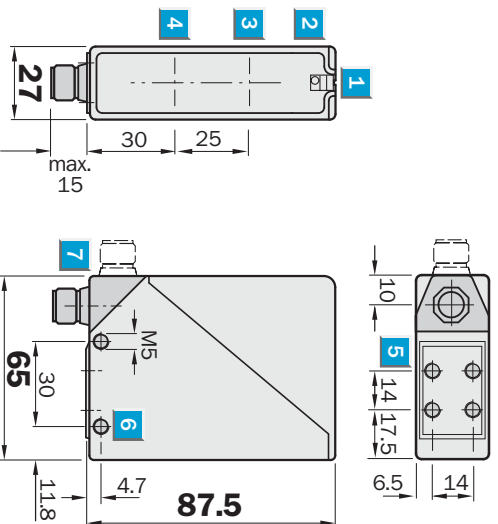

- **Marking:** Ex II 2G EEx ia IIC T4 according to Directive 94/9/EC (ATEX)
- According to category 2G
- **Switching output:** EN 60947-5-6 (NAMUR)
- **Red light**
- **Device plug can be rotated through 90°**

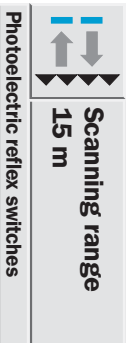

See chapter Accessories

Cables and connectors
Mounting systems
Reflectors
Power supply units

Adjustments possible

WL 24-X 2301
WL 24-X 4301

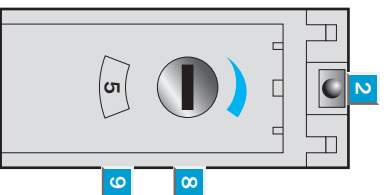

- 1 Alignment sight
- 2 LED signal strength indicator
- 3 Centre of receiver's optical axis
- 4 Centre of transmitter's optical axis
- 5 M5 threaded mounting hole – 8 mm deep
- 6 M5 threaded mounting hole
- 7 PG screw connection or plug M12; rotatable
- 8 Sensitivity adjustment
- 9 Sensitivity indicator

Connection types

WL 24-X 2301

WL 24-X 4301

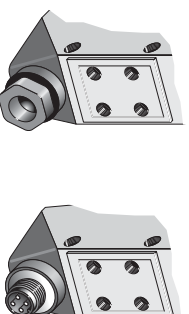

PG 9, terminals



4-pin, M12

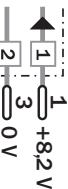

Technical data	WL 24-	X 2301	X 4301							
-----------------------	--------	--------	--------	--	--	--	--	--	--	--

Scanning range , max. ψ /p/on reflector	15 m/PL 80 A									
Sensitivity	Adjustable									
Light source ¹⁾, light type	LED, red light									
Light spot diameter	Approx. 145 mm at 8 m									
Supply voltage V_S ²⁾	8.2 V DC (R_I approx. 1 k Ω) (5 V ... 13.5 V) ³⁾									
Residual ripple ⁴⁾	0.4 V _{pp}									

EC-type examination certificate	PTB 03 ATEX 2104									
Explosion protection	Type of protection "intrinsic safety"									
Input voltage U_i , max.	15.5 V									
Input current I_i , max.	53 mA									
Input power P_i , max.	100 mW									
Internal capacity C_i , max.	80 nF									
Internal inductivity L_i , max.	80 μ H									
Ambient temperature T_A	Operation: $-20\text{ }^\circ\text{C} < T_A < +50\text{ }^\circ\text{C}$									
Output/current consumption	Control current dependent on switching state (to EN 60947-5-6 (NAMUR))									
Light beam not interrupted	$\geq 2.2\text{ mA}$									
Light beam interrupted	$\leq 1\text{ mA}$									

Switching mode	Light-switching									
Response time ⁵⁾	$\leq 10\text{ ms}$									
Max. switching frequency ⁶⁾	50/s									
Connection types	Plug									
	Terminal connection									

VDE protection class ⁷⁾	<input type="checkbox"/> <input checked="" type="checkbox"/>									
Circuit protection ⁸⁾	A, C									
Enclosure rating	IP 67									
Ambient temperature T_A	Storage: $-25\text{ }^\circ\text{C} \dots +70\text{ }^\circ\text{C}$ Approx. 330 g									
Weight										
Housing material	Zinc die-cast housing									

- ¹⁾ Average service life 100,000 h at $T_A = +25\text{ }^\circ\text{C}$
- ²⁾ Supply with switching amplifier EN 2 Ex
- ³⁾ Limit values
- ⁴⁾ May not exceed or fall short of V_S tolerances
- ⁵⁾ Signal transfr. time with resistive load
- ⁶⁾ With light/dark ratio 1:1
- ⁷⁾ Reference voltage 50 V DC
- ⁸⁾ A = V_S connections reverse-polarity protected
C = Interference pulse suppression

Scanning range and operating reserve

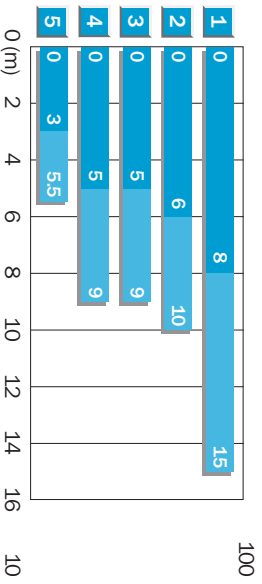

■ Operating range ■ Scanning range, max. typical

Reflector type	Operating range
1 PL 80 A	0 ... 8 m
2 PL 50 A	0 ... 6 m
3 PL 40 A	0 ... 5 m
4 PL 30 A	0 ... 5 m
5 PL 20 A	0 ... 3 m

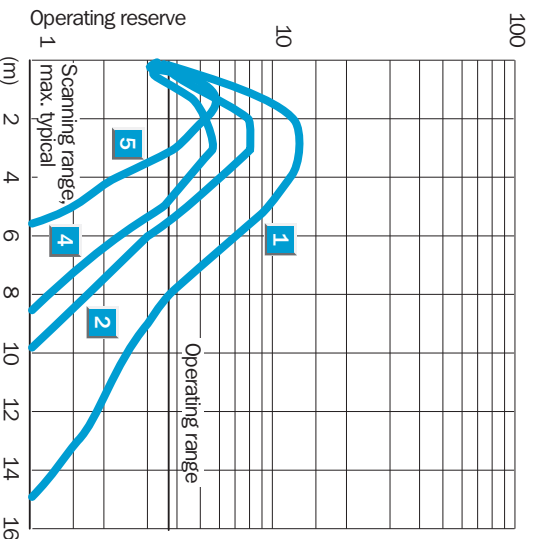

Order information	
Type	Order no.
WL 24-X 2301	1 011 972
WL 24-X 4301	1 011 971

 **Scanning range**
40 m

Through-beam photoelectric switches

- **Marking:**  II 2G EEx ia
- IIC T4 according to Directive 94/9/EC (ATEX)
- According to category 2G
- **Switching output:**
- EN 60947-5-6 (NAMUR)
- **Red light**
- **Device plug can be rotated through 90°**

Dimensional drawing

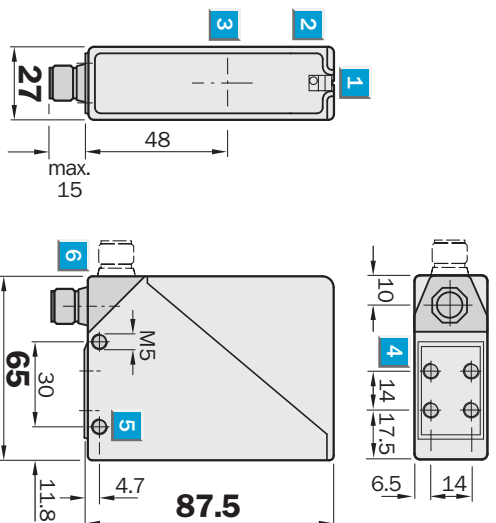

Adjustments possible

WS/WE 24-X 230I
WS/WE 24-X 430I

- 1 Alignment sight
- 2 LED signal strength indicator on WE
- 3 Power indicator on WS
- 4 Middle of optical axis
- 5 M5 threaded mounting hole – 8 mm deep
- 6 M5 threaded mounting hole
- 7 PG screw connection or plug M12, rotatable
- 8 Sensitivity indicator



Connection types
WS/WE 24-X 230I

WS/WE 24-X 430I

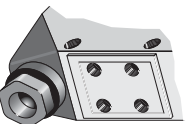
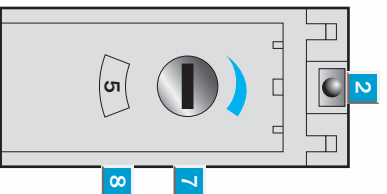

PG 9, terminals



4-pin, M12

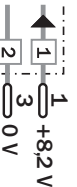

See chapter Accessories
Cables and connectors
Mounting systems
Power supply units



Technical data	WS/WE 24-	X 2301	X 4301						
-----------------------	-----------	--------	--------	--	--	--	--	--	--

Scanning range , max. typical	0 ... 40 m
Sensitivity	Adjustable
Light source ¹⁾ , light type	LED, red light
Light spot diameter	Approx. 450 mm at 25 m
Supply voltage V_S ²⁾	8.2 V DC (R _i approx. 1 k Ω) (5 V ... 13.5 V) ³⁾
Residual ripple ⁴⁾	0.4 V _{pp}

EC-type examination certificate PTB 03 ATEX 2103

Explosion protection Type of protection "intrinsic safety"

Input voltage U_i , max.	15.5 V
Input current I_i , max.	53 mA
Input power P_i , max.	100 mW
Internal capacity C_i , max.	WS: 15 nF/WE: 80 nF
Internal inductivity L_i , max.	150 μ H
Ambient temperature T_A	Operation: -20 °C < T_A < +50 °C

Output/current consumption	Control current dependent on switching state (to EN 60947-5-6 (NAMUR))
-----------------------------------	--

Sender permanent	≥ 2.2 mA
Light beam not interrupted	≥ 2.2 mA
Light beam interrupted	≤ 1 mA

Switching mode	Light-switching
Response time ⁵⁾	≤ 10 ms
Max. switching frequency ⁶⁾	50/s

Connection types	Plug
	Terminal connection

VDE protection class ⁷⁾	<input type="checkbox"/> <input checked="" type="checkbox"/>
---	--

Circuit protection ⁸⁾	A, C
---	------

Enclosure rating	IP 67
-------------------------	-------

Ambient temperature T_A	Storage: -25 °C ... +70 °C
---	----------------------------

Weight	Approx. 330 g
---------------	---------------

Housing material	Zinc die-cast housing
-------------------------	-----------------------

- ¹⁾ Average service life 100,000 h at $T_A = +25$ °C
- ²⁾ Supply with switching amplifier EN 2 Ex
- ³⁾ Limit values
- ⁴⁾ May not exceed or fall short of V_S tolerances
- ⁵⁾ Signal transit time with resistive load
- ⁶⁾ With light/dark ratio 1:1
- ⁷⁾ Reference voltage 50 V DC
- ⁸⁾ A = V_S connections reverse-polarity protected
C = Interference pulse suppression

Scanning range and operating reserve

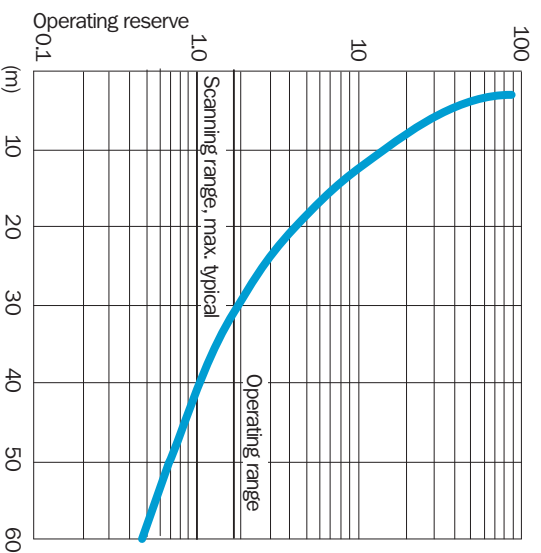
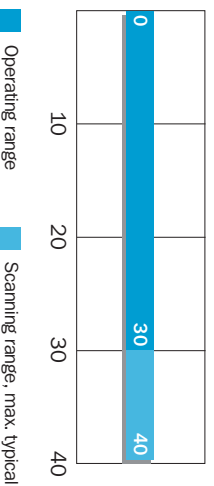

Order information	
Type	Order no.
WS/WE 24-X 2301	1 011 516
WS/WE 24-X 4301	1 011 517

Dimensional drawing

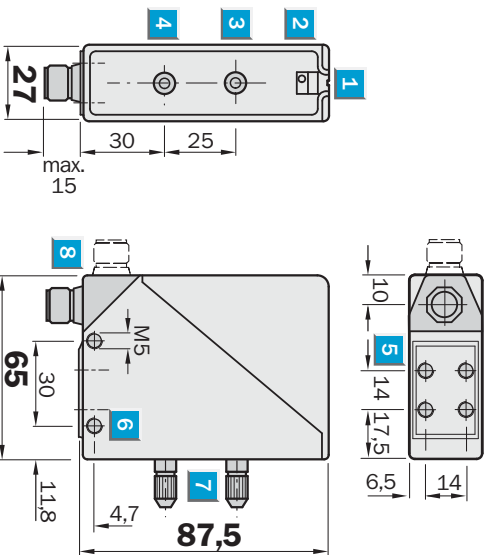

	Scanning range ... 100 mm (max. 1000 mm)
	Through-beam system
	Scanning distance ... 25 mm
	Proximity system

- **Marking:** II 2G EEx ia IIC T4 ac-cording to Directive 94/9/EC (ATEX)
- **Switching output:**
EN 60947-5-6 (NAMUR)
- **Red light**
- **Fibre-optic cable, exchangeable**



See chapter Accessories
Cables and connectors
Mounting systems
Fibre-optic cables
Power supply units

Adjustments possible

WLL 24-X 2301
WLL 24-X 4301

- 1 Alignment sight
- 2 LED signal strength indicator
- 3 Centre of receiver's optical axis
- 4 Centre of transmitter's optical axis
- 5 M5 threaded mounting hole – 8 mm deep
- 6 M5 threaded mounting hole
- 7 Connector for fibre-optic cable
- 8 PG screw connection or plug M12; rotatable
- 9 Sensitivity adjustment
- 10 Sensitivity indicator

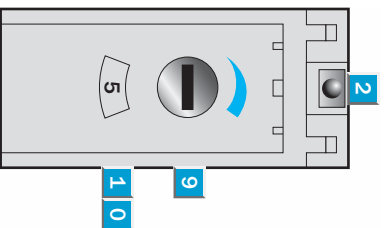

Connection types

WLL 24-X 2301

WLL 24-X 4301

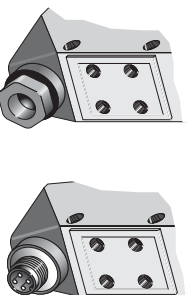

PG 9, terminals

4-pin, M12

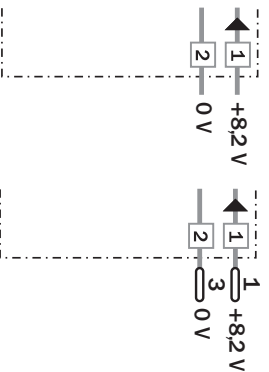

Technical data	WLL 24-	X 2301	X 4301						
-----------------------	---------	--------	--------	--	--	--	--	--	--

Scanning range , through-beam system	100 mm with LL3-TB02								
Scanning distance , proximity system	1000 mm with tip adapter LL3-TA01								
Fibre-optic cable	25 mm with LL3-DB01								
	See chapter Accessories								
	"Fibre-optic cables"								
Sensitivity	Adjustable								
Light source ¹⁾, light type	LED, red light								
Supply voltage V_S ²⁾	8.2 V DC (R _i approx. 1 kΩ)								
	(5 V ... 13.5 V) ³⁾								
Residual ripple ⁴⁾	0.4 V _{pp}								

EC-type examination certificate	PTB 03 ATEX 2104								
Explosion protection	Type of protection "intrinsic safety"								
Input voltage U _i , max.	15.5 V								
Input current I _i , max.	53 mA								
Input power P _i , max.	100 mW								
Internal capacity C _i , max.	80 nF								
Internal inductivity L _i , max.	80 μH								
Ambient temperature T _A	Operation: -20 °C < T _A < +50 °C								
Output/current consumption	Control current dependent on switching state (to EN 60947-5-6 (NAMUR))								
Light beam not interrupted	≥ 2.2 mA								
Light beam interrupted	≤ 1 mA								
Switching mode	Light-switching								
Response time ⁵⁾	≤ 10 ms								
Max. switching frequency ⁶⁾	50/s								
Connection types	Plug								
	Terminal connection								
VDE protection class ⁷⁾	<input type="checkbox"/> <input checked="" type="checkbox"/>								
Circuit protection ⁸⁾	A, C								
Enclosure rating	IP 65								
Ambient temperature T_A	Storage: -25 °C ... +70 °C								
Weight	Approx. 330 g								
Housing material	Zinc die-cast housing								



¹⁾ Average service life 100,000 h at T_A = +25 °C
²⁾ Supply with switching amplifier EN 2 Ex

³⁾ Limit values
⁴⁾ May not exceed or fall short of V_S tolerances

⁵⁾ Signal transit time with resistive load
⁶⁾ With light/dark ratio 1:1
⁷⁾ Reference voltage 50 V DC

⁸⁾ A = V_S connections reverse-polarity protected
 C = Interference pulse suppression

Order information	
Type	Order no.
WLL 24-X 2301	1 011 562
WLL 24-X 4301	1 012 711

	Photoelectric proximity switches BGS
	Photoelectric reflex switches
	Through-beam photoelectric switches

Ready-to-fit and Standard-compliant - Cat. 3D/3G Photoelectric Switches for Explosive Areas



The Category 3D/3G photoelectric switches from SICK are equipped with a metal housing. This housing meets the demanding requirements of the Standard and therefore offers a ready-to-fit solution in respect of the standard.

Product range:

- **W18-3EX:** Compact dimensions, accurate background suppression, insensitive to optical interference, sensor range up to 1,000 mm and up to 7m as a photoelectric reflex switch,

“EX” series modules are designed for explosive areas in ignition protection Type “n” according to EN 50021. Hence, they conform to Categories 3G and 3D, based on the new 94/9/EC (ATEX) Directive, and can be used in the areas “Zone 2 (gas)” and “Zone 22 (non-conductive dust)”. In addition to limit values for temperature, performance or UV resistance, the Standard stipulates a mechanical strength which cannot be achieved with standard sensors.

- **WTR2EX:** Economical solution for scanning distances up to 900 mm,
- **WL24-2EX:** The powerful photoelectric switch with a range of up to 22 m.

► Filling of building material.

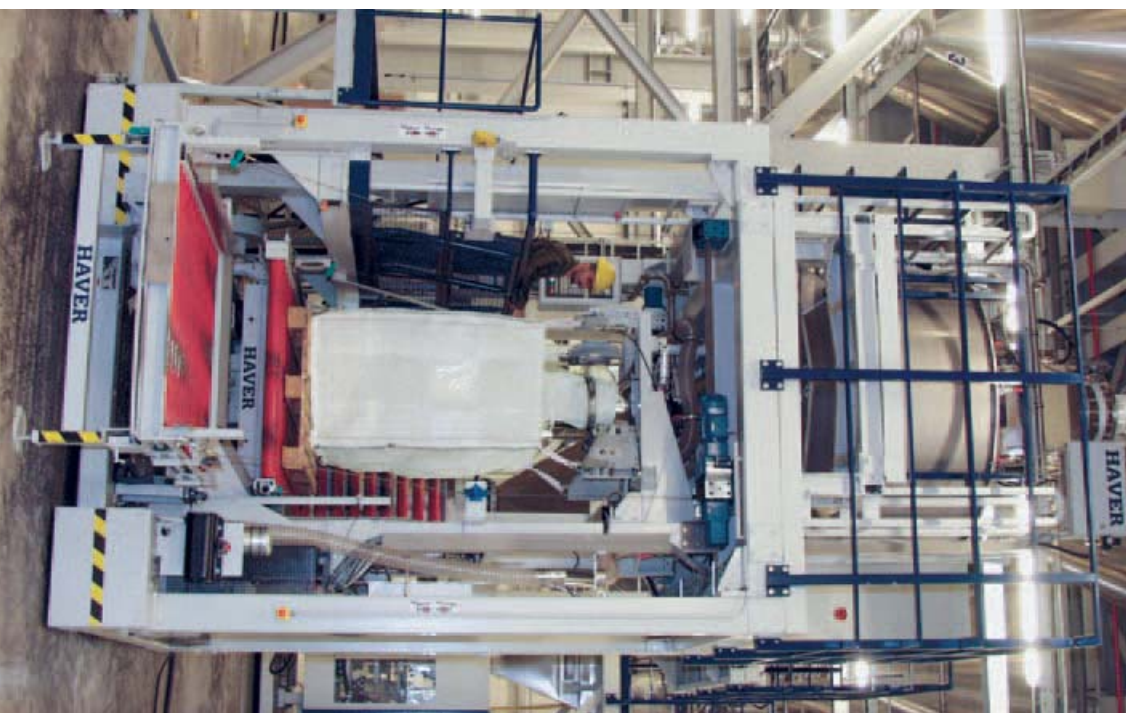

▼ WTB27-3Ex photoelectric proximity switch detects the presence of pallets.



▲ Smart solution: WTB27-3Ex photoelectric proximity switch and protection housing.



Dimensional drawing

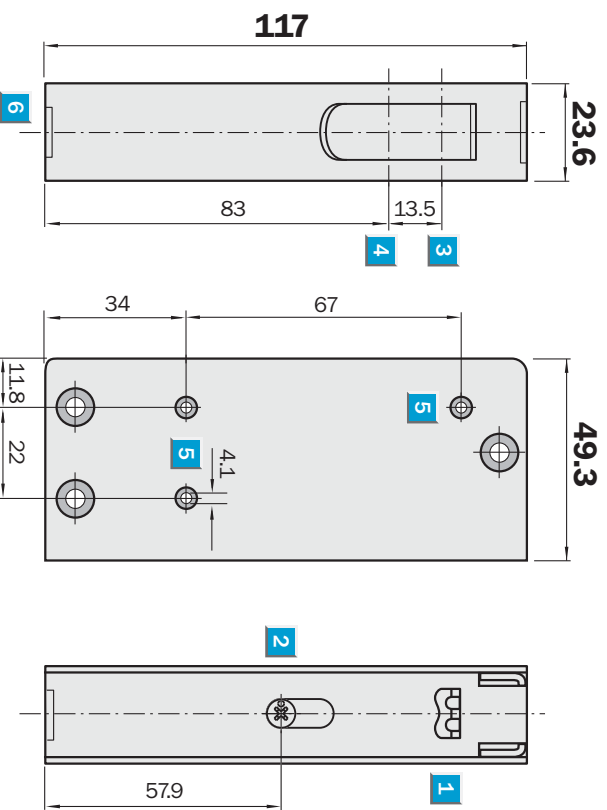

- Ready-to-fit, Standard-compliant design: sensor + protective housing
- Complies with Categories 3D and 3G according to 94/9/EC (ATEX) Directive
- Accurate background suppression
- Insensitive to optical interference

 Scanning distance
50 ... 1,000 mm

Photoelectric proximity switch

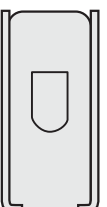

Adjustments possible

WT18X-3P920

- 1 Status indicator LEDs
- 2 Scanning distance adjustment
- 3 Middle of optical axis, sender
- 4 Middle of optical axis, receiver
- 5 Mounting holes \varnothing 4.1 mm
- 6 Connector

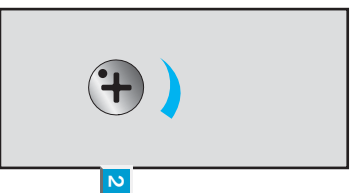

Connection type
WT18X-3P920

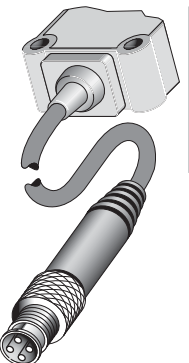

M12, 4-pin

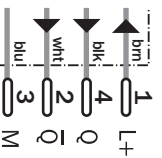

See chapter Accessories

Connector, M12, 4-pin

Mounting systems

WT18X-3

P920

Scanning distance typ. max.	50 ... 1,000 mm ¹⁾
Adjustment of operating distance	Potentiometer
Light source, light type	LED, Infrared light ²⁾
Light spot diameter	30 mm at 600 mm distance
Supply voltage V_s	DC 10 ... 30 V ³⁾
Ripple	< 5 V _{SS} ⁴⁾
Power consumption	< 45 mA ⁵⁾
Switching outputs	PNP antivalent
Output current I _a max	< 100 mA
Response time	< 700 μs ⁶⁾
Switching frequency	700 Hz ⁷⁾
Connection type	Cable with plug, M12, 4-pin, 290 mm ⁸⁾
Ex marking (ATEX)	EX II 3G EEx nA II T4 X EX II 3D IP67 T70 °C ⁹⁾
VDE protection class	□ ¹⁰⁾
Circuit protection	V _s connections reverse-polarity protected / All outputs short-circuit protected / Interference suppression
Enclosure rating	IP 67
Ambient temperature operation	-20 °C ... +50 °C
Ambient temperature storage	-40 °C ... +75 °C
Weight	Approx. 300 g
Housing material	ABS / stainless steel 1.4301

¹⁾ Object with 90 % remission (based on standard white to DIN 5033)
²⁾ Average service life 100,000 h at T_a = +25 °C

³⁾ Limit values, reverse-polarity protected operation in short-circuit protected network max. 8 A
⁴⁾ may not exceed or fall short of

V_s tolerances
⁵⁾ without load
⁶⁾ Signal transit time with resistive load
⁷⁾ with light/dark ratio 1:1

⁸⁾ do not bend below 0 °C
⁹⁾ conformity with directives, Explosion prevention: Directive 94/9/EC
¹⁰⁾ Reference voltage 50 V DC

Scanning range

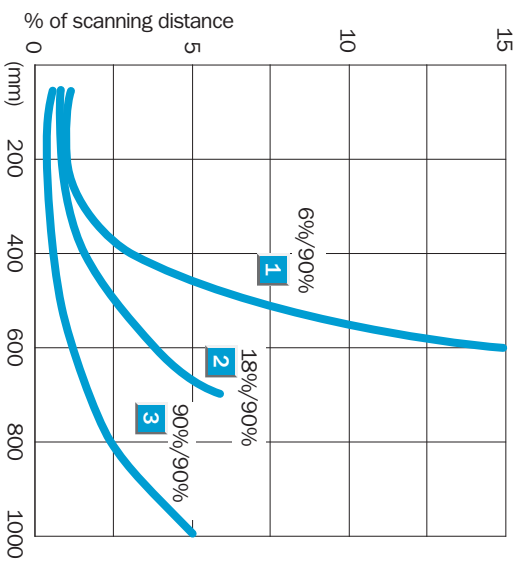
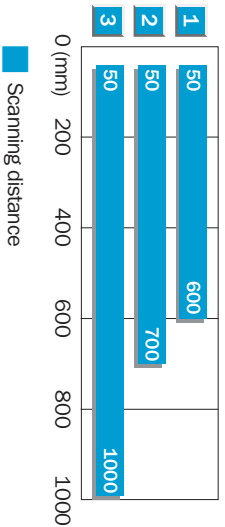

- 1 Scanning distance on black, 6% remission
- 2 Scanning distance on grey, 18% remission
- 3 Scanning distance on white, 90% remission

Ordering information	
Type	Order no.
WT18X-3P920	1 029 901

Dimensional drawing

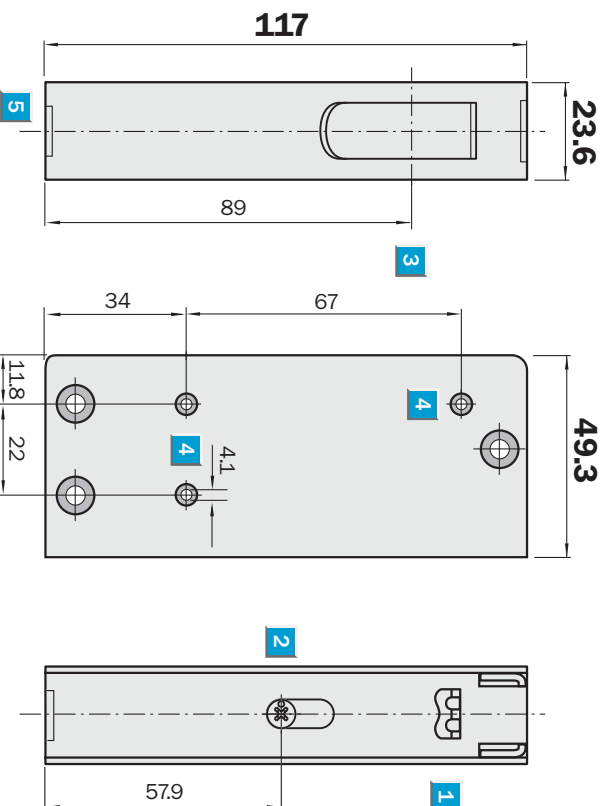

 **Scanning range**
0 ... 7 m

Photoelectric reflex switch

- Ready-to-fit, Standard-compliant design: sensor + protective housing
- Complies with Categories 3D and 3G according to 94/9/EC (ATEX) Directive
- Autocollimation principle
- Insensitive to optical interference

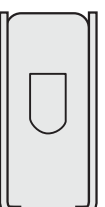

1

Adjustments possible

WL18X-3P930

- 1 Status indicator LEDs
- 2 Sensitivity control
- 3 Middle of optical axis
- 4 Mounting holes Ø 4.1 mm
- 5 Connector



2

Connection type

WL18X-3P930

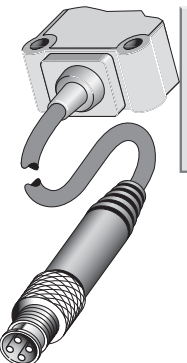

M12, 4-pin

See chapter Accessories

Connector, M12, 4-pin

Mounting systems

Reflectors

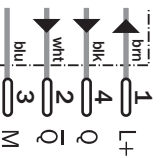

WL18X-3

P930

Scanning range typ. max.	0 ... 7 m
Relating to	Reflector PL80A
Sensitivity adjustment	Potentiometer
Light source, light type	LED, visible red light ¹⁾
Light spot diameter	40 mm at 2 m distance
Angle of dispersion	1.5°
Polarisation filter	✓
Supply voltage V_s	DC 10 ... 30 V ²⁾
Ripple	< 5 V _{SS} ³⁾
Power consumption	< 30 mA ⁴⁾
Switching outputs	PNP antivalent
Output current I _g max	< 100 mA
Response time	500 µs ⁵⁾
Switching frequency	1,000 Hz ⁶⁾
Connection type	Cable with plug, M12, 4-pin, 290 mm ⁷⁾
Ex marking (ATEX)	EX II 3D IP67 T70 °C EX II 3G EEx nA II T4 X ⁸⁾
VDE protection class	□ ⁹⁾
Circuit protection	V _s connections reverse-polarity protected / All outputs short-circuit protected / Interference suppression
Enclosure rating	IP 67
Ambient temperature operation	-20 °C ... +50 °C
Ambient temperature storage	-40 °C ... +75 °C
Weight	Approx. 300 g
Housing material	ABS / stainless steel 1.4301
Included with delivery	Securing clip for connector

¹⁾ Average service life 100,000 h at I_a = +25 °C

²⁾ Limit values, reverse-polarity protected operation in short-circuit protected

⁴⁾ without load

⁵⁾ Signal transit time with resistive load

⁶⁾ with light/dark ratio 1:1

⁷⁾ do not bend below 0 °C

⁸⁾ Conformity with directives.

⁹⁾ Explosion prevention: Directive 94/9/EC

⁹⁾ Reference voltage 50 V DC

Scanning range and operating reserve

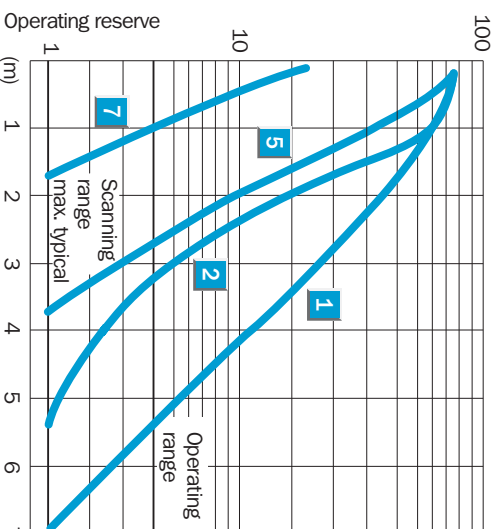
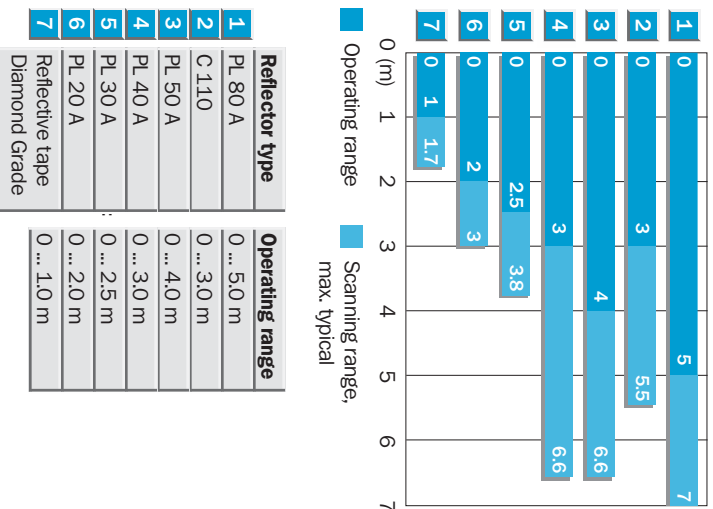

Ordering information	
Type	WL18X-3P930
Order no.	1 029 902

Dimensional drawing

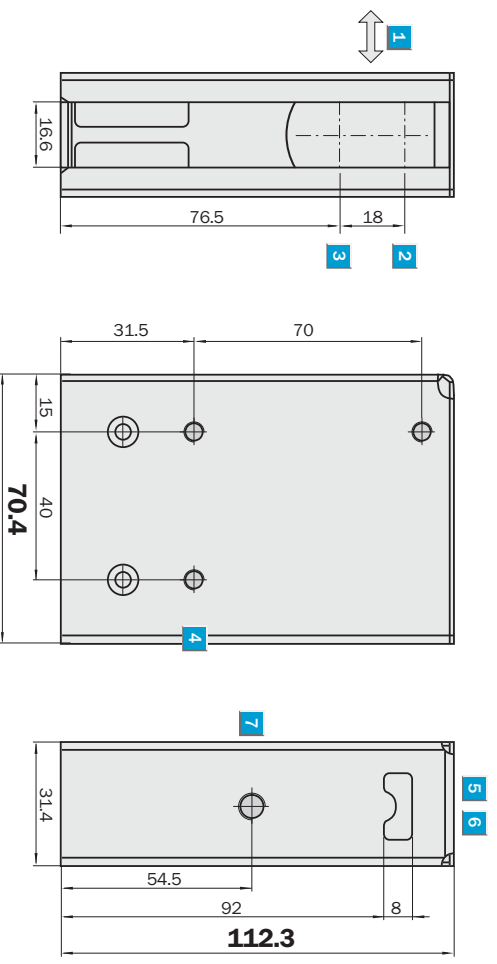

Scanning distance
30 ... 1,600 mm

Photoelectric proximity switch

- Category 3D and 3G (ATEX)
- Standard-compliant: sensor + protective housing
- Infrared light, very long scanning distance
- Reliable in industrial environments; secure against the effects of ambient light, unwanted optical reflections and other sensors mounted adjacently



Adjustments possible

WTB27X-3P1811

- 1 Standard direction of the material being scanned
- 2 Optical axis sender
- 3 Optical axis receiver
- 4 Mounting hole Ø 5.2 mm
- 5 LED indicator green; power on
- 6 LED indicator yellow; status of received light beam
- 7 Adjustment of operating distance: Pot

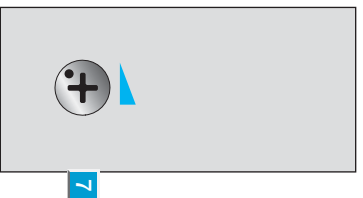

Connection type

WTB27X-3P1811

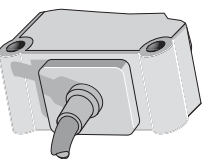

4 x 0.25 mm²

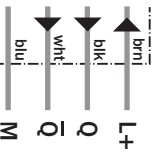

See chapter Accessories
Mounting systems

Dimensional drawing

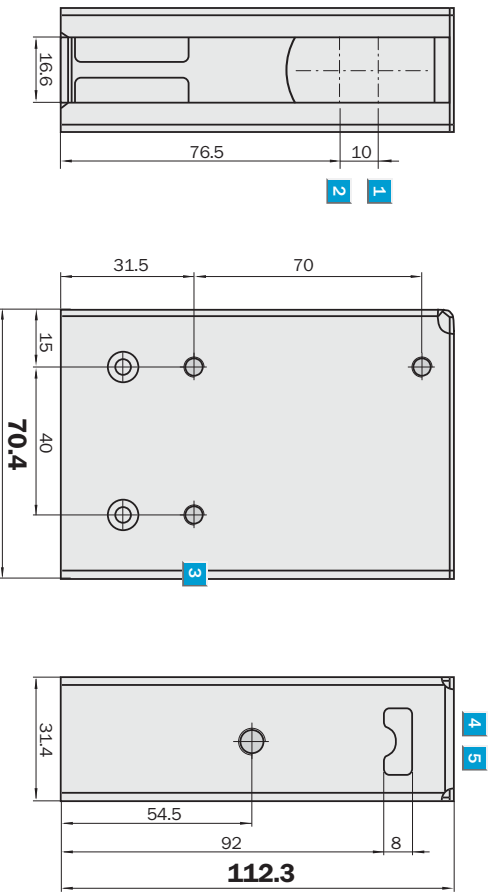

Scanning range
0 ... 35 m

Through-beam photoelectric switch

- Category 3D and 3G (ATEX)
- Standard-compliant: sensor + protective housing
- High intensity red light for easier alignment
- Long range, high operating reserve



Adjustments possible

WSE27X-3P1830

- 1 Optical axis sender
- 2 Optical axis receiver
- 3 Mounting hole Ø 5.2 mm
- 4 LED indicator green; power on
- 5 LED indicator yellow; status of received light beam



Connection type

WSE27X-3P1830

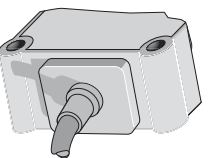

4 x 0.25 mm²

Sender

Receiver

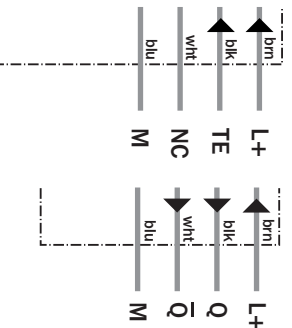

See chapter Accessories

Mounting systems

Dimensional drawing

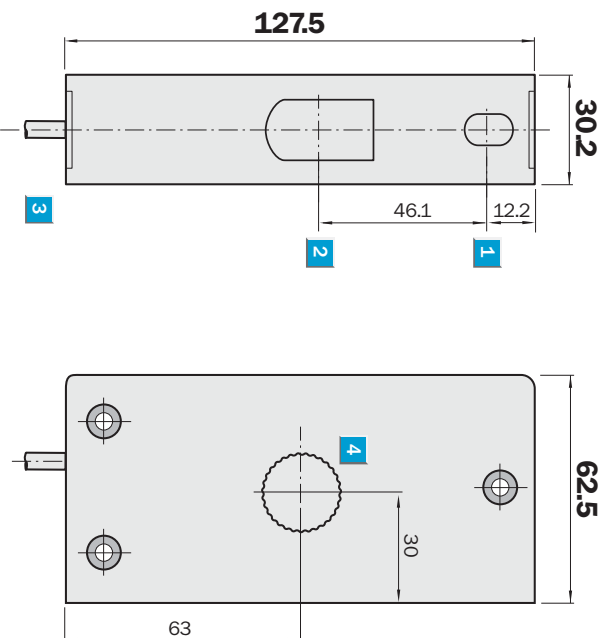

- Ready-to-fit, Standard-compliant design: sensor + protective housing
- Complies with Categories 3D and 3G according to 94/9/EC (ATEX) Directive
- Accurate background suppression
- Fixing hole for clamp holder

Scanning distance
300 ... 900 mm

Photoelectric proximity switch



Adjustments possible

WTR2-P511S21

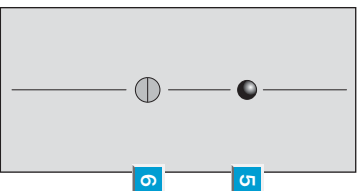

- 1 Middle optical axis, sender
- 2 Middle optical axis, receiver
- 3 Connection
- 4 Fixing hole for clamp holder
- 5 Reception display
- 6 Scanning distance adjustment

Connection type

WTR2-P511S21



M12, 4-pin

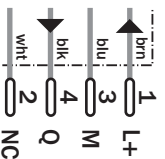

See chapter Accessories

Connector, M12, 4-pin

Mounting systems

WTR2-P5

11S21

Scanning distance typ. max.	300 ... 900 mm
Light source, light type	LED, infrared light
Light spot diameter	Approx. 40 mm
Supply voltage V_s	DC 10 ... 30 V ¹⁾
Ripple	< 5 V _s ²⁾
Power consumption	≤ 25 mA ³⁾
Switching outputs	PNP
Switching mode	Light-switching
Output current $I_{a,max}$	100 mA
Switching frequency	250 Hz
Connection type	Cable with plug, M12, 4-pin, 270 mm ⁴⁾
Ex marking (ATEX)	EX II 3D IP67 T70 °C ⁵⁾
VDE protection class	□
Circuit protection	In-/outputs short-circuit protected / All outputs short-circuit protected / Interference suppression
Enclosure rating	IP 54
Ambient temperature operation	-20 °C ... +50 °C
Ambient temperature storage	-40 °C ... +75 °C
Weight	Approx. 550 g
Housing material	ABS / stainless steel 1.4301
Included with delivery	Securing clip for connector

¹⁾ Limit values
²⁾ may not exceed or fall short of

V_s tolerances
³⁾ without load

⁴⁾ do not bend below 0 °C

⁵⁾ conformity with directives, Explosion prevention: Directive 94/9/EC

Scanning distance

1	60	900
2	20	900
3	5	900

0 (mm) 200 400 600 800 1000

- 1** Scanning distance on black, 6% remission
- 2** Scanning distance on grey, 18% remission
- 3** Scanning distance on white, 90% remission

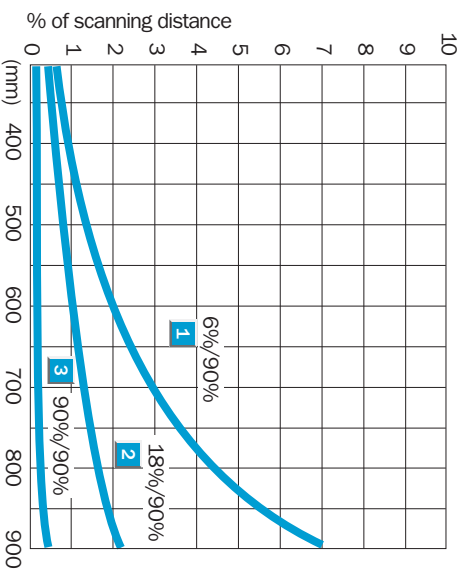

Ordering information	
Type	WTR2-P511S21
Order no.	1 029 241

Dimensional drawing

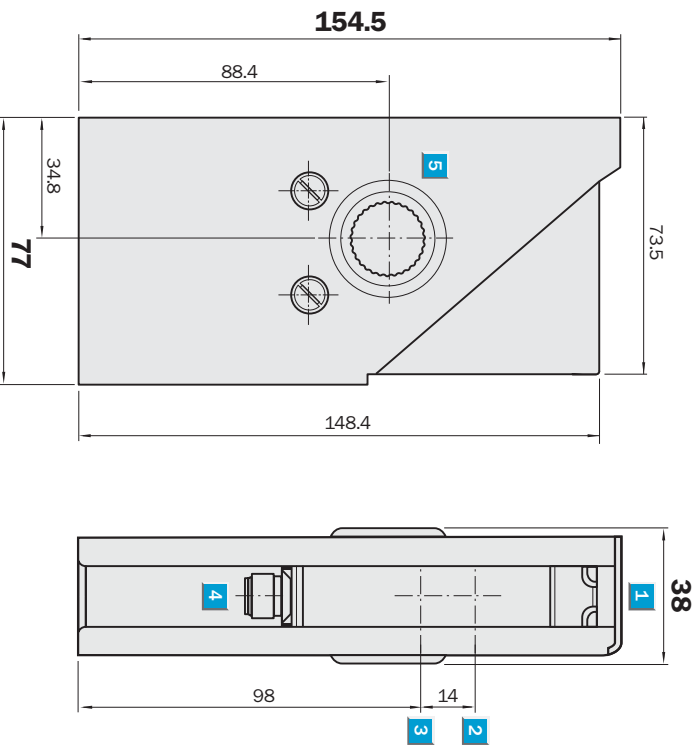

Scanning range
0 ... 22 m

Photoelectric reflex switch

- Ready-to-fit, Standard-compliant design: sensor + protective housing
- Complies with Categories 3D and 3G according to 94/9/EC (ATEX) Directive
- Very large range
- Fixing hole for clamp holder



Adjustments possible

WL24-2V530S06

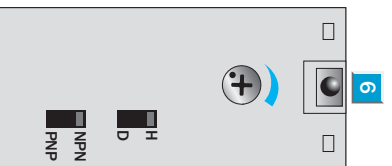

- 1 Reception display
- 2 Middle optical axis, sender
- 3 Middle optical axis, receiver
- 4 Connection
- 5 Fixing hole for clamp holder
- 6 Reception display
- 7 Sensitivity adjuster
- 8 Light/dark switch
- 9 NPN/PNP selector switch

Connection type
WL24-2V530S06

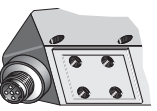

M12, 5-pin

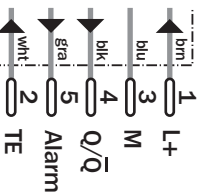

See chapter Accessories

Connector, M12, 5-pin

Mounting systems

Reflectors

WL24-2V530

S06

Scanning range typ. max.	0 ... 22 m
Scanning range, recommended	0 ... 15 m
Relating to	Reflector PL80A
Light source, light type	LED, red light ¹⁾
Light spot diameter	Approx. 250 mm at 15 m distance
Polarisation filter	✓
Supply voltage V_s	DC 10 ... 30 V ²⁾
Ripple	< 5 V _{ss} ³⁾
Power consumption	≤ 50 mA ⁴⁾
Switching outputs	PNP or NPN, Q or Q not
Output current I _a max	100 mA
Response time	≤ 500 µs ⁵⁾
Switching frequency ⁶⁾	1,000 Hz ⁶⁾
Test input sender off	TE to 0 V
Connection type	Connector, M12, 5-pin
Ex marking (ATEX)	EX II 3D IP67 T70 °C EX II 3G EEx nA II T4 X ⁷⁾ □ ⁸⁾
VDE protection class	Vs connections reverse-polarity protected / Output Q and Q not short-circuit protected / Interference suppression
Circuit protection	IP 67
Enclosure rating	-20 °C ... +50 °C
Ambient temperature operation	-40 °C ... +75 °C
Ambient temperature storage	Approx. 800 g
Weight	Zinc die-cast
Housing material	

¹⁾ Average service life 100,000 h at T_a = +25 °C
²⁾ Limit values

³⁾ may not exceed or fall short of V_s tolerances
⁴⁾ without load

⁵⁾ Signal transit time with resistive load
⁶⁾ with light/dark ratio 1:1
⁷⁾ conformity with directives: Explosion

⁸⁾ prevention: Directive 94/9/EC
⁹⁾ Reference voltage 50 V DC

Scanning range and operating reserve

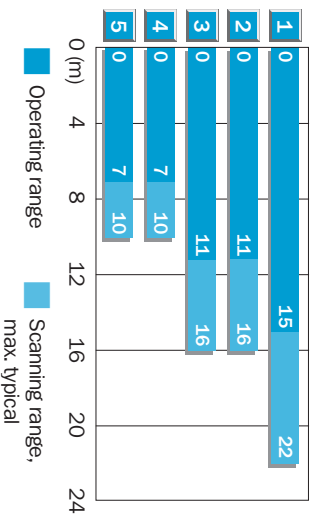

Reflector type	Operating range
1	PL 80 A
2	PL 50 A
3	PL 40 A
4	PL 30 A
5	PL 20 A

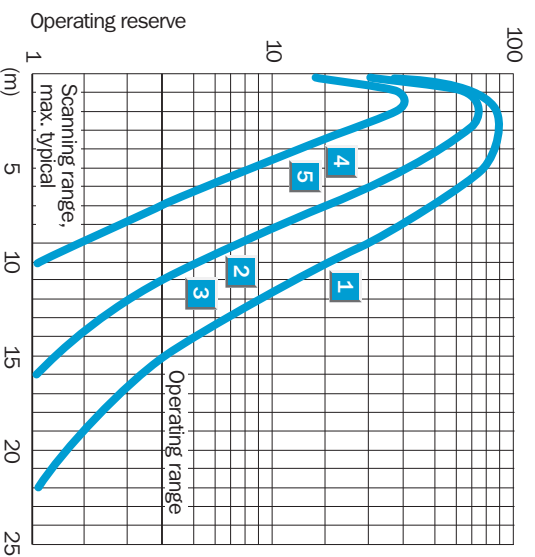

Ordering information	
Type	WL24-2V530S06
Order no.	1 027 613